

EVALUASI SMART OPERATION BOILER CFB PLTU

Oleh

Dr. Abrar Riza dan Tim

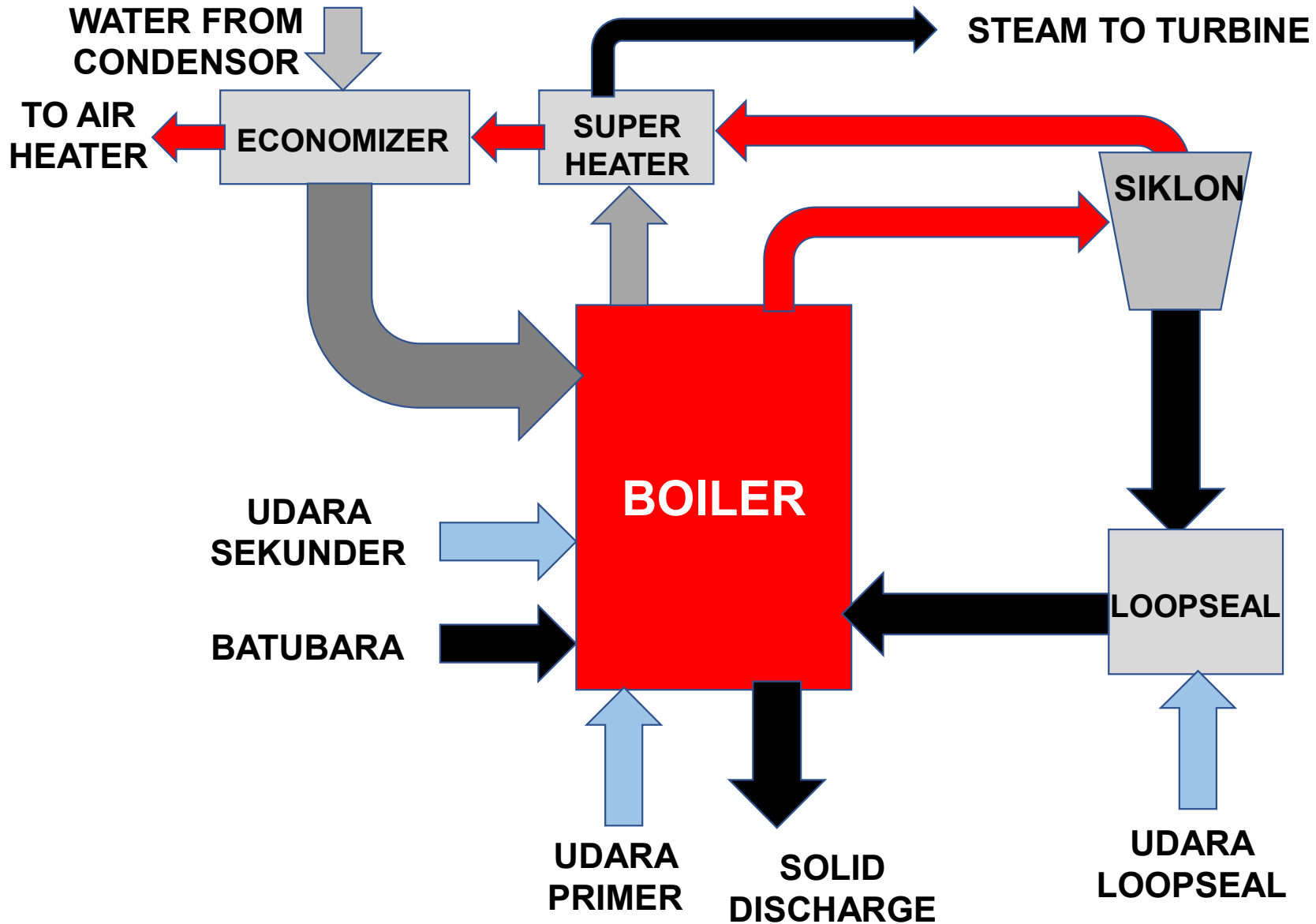

TAHAP 1

ROLL CRUSHER

INLET

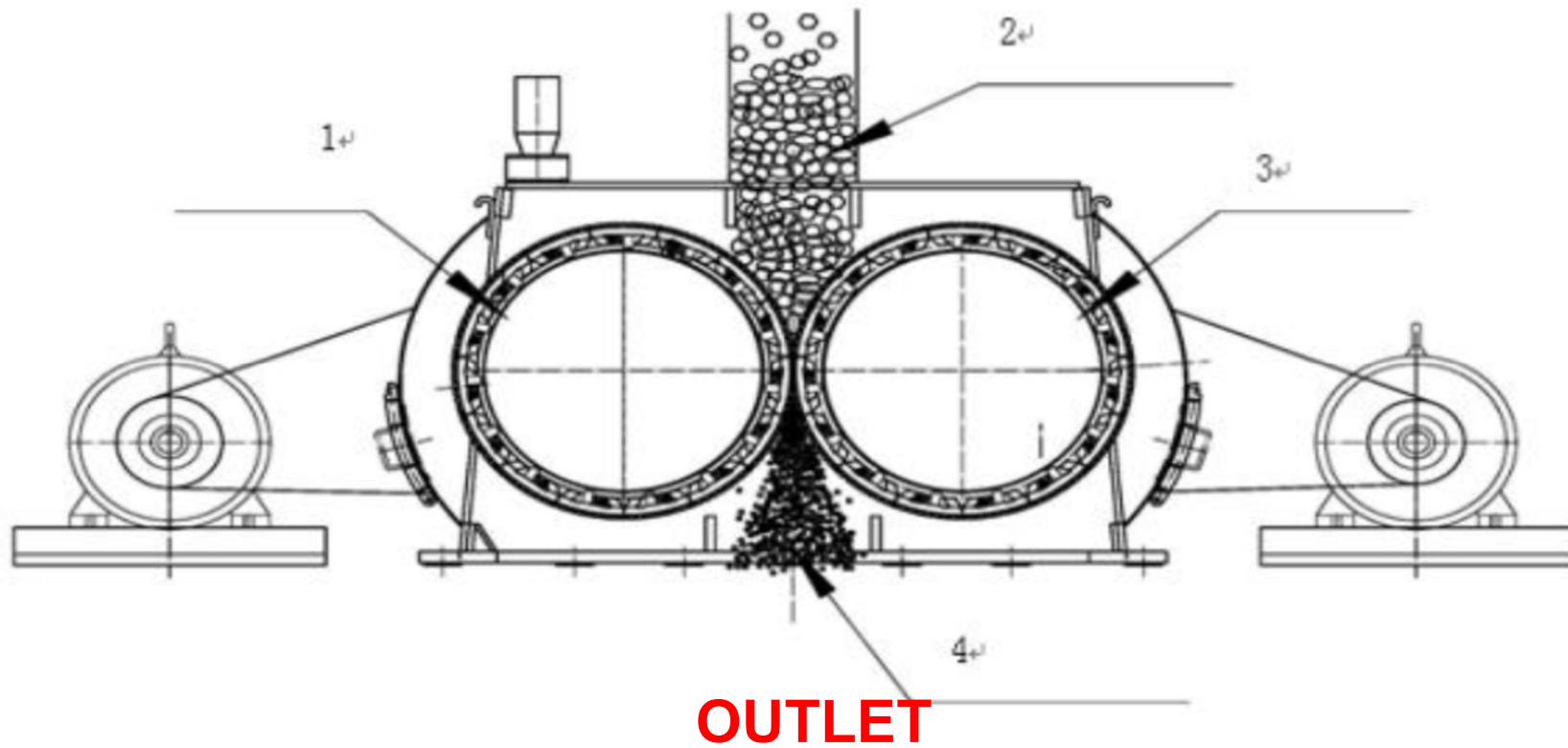

Design Criteria (Equipment Material, Sizing, Etc)

Type specification: HL2PG-300B1		output per hour: 300 t/h			
Maximum feeding size ≤ 70 mm		discharging granularity ≤ 15 mm			
Equipment external dimensions (L \times W \times H) mm		5400 \times 4870 \times 3920			
Weight (kg)		21800			
Maximum external dimension for lifting (L \times W \times H) mm		2690 \times 2300 \times 1420			
Maximum hoisting weight (kg)		(rack + working device) 13000			
Maximum repair dimension (L \times W \times H) mm		2100 \times ϕ 1100			
Maximum repair weight (kg)		4200			
Main motor	Model	Voltage	Power	Quantity	External dimension (mm) (L \times W \times H)
	Y315M-6	400V	90	1	1300 \times 645 \times 845
	Y315M-6	400V	90	1	1300 \times 645 \times 845

Sample was analysed for the following quality characteristics as requested by Ms. Rere B, on dated : January 18, 2019.

Customer sample ID : Lab sample ID No.		PLN-UPDK-BPP		METHOD
		KT 19. 00237		
Date of analysis		January 19, 2019		ASTM D4749-2012
Size Fraction (mm)		Fractional	Cumulative Undersize	
'+ 16	%	43.77	100.00	
'- 16 + 12.5	%	5.95	56.23	
'- 12.5 + 8.0	%	12.97	50.28	
'- 8.0 + 4.0	%	12.67	37.31	
'- 4.0 + 2.0	%	9.04	24.64	
'- 2.0 + 1.0	%	7.99	15.60	
'- 1.0 + 0.5	%	2.30	7.61	
'- 0.5	%	5.31	5.31	

Note : ASTM (American Society for Testing and Materials)

TERLIHAT PADA HASIL ANALISA INI UTK DISTRIBUSI UKURAN BATUBARA MASUK KE BOILER MASIH BANYAK UKURAN BESARNYA SEHARUSNYA DILAKUKAN SECREENER DENGAN UKURAN DIATAS 10 mm DIKEMBALIKAN

CAUSAL EFFECT DARI UKURAN BATUBARA UNTUK PEMBAKARAN DI
CFB PLTU TELUK BALIKPAPAN YANG TIDAK SESUAI



TAHAP 2

Hubungan laju alir batubara coal feeder (Ton/Jam) terhadap Beban yang dihasilkan (MW) Bulan April 2020

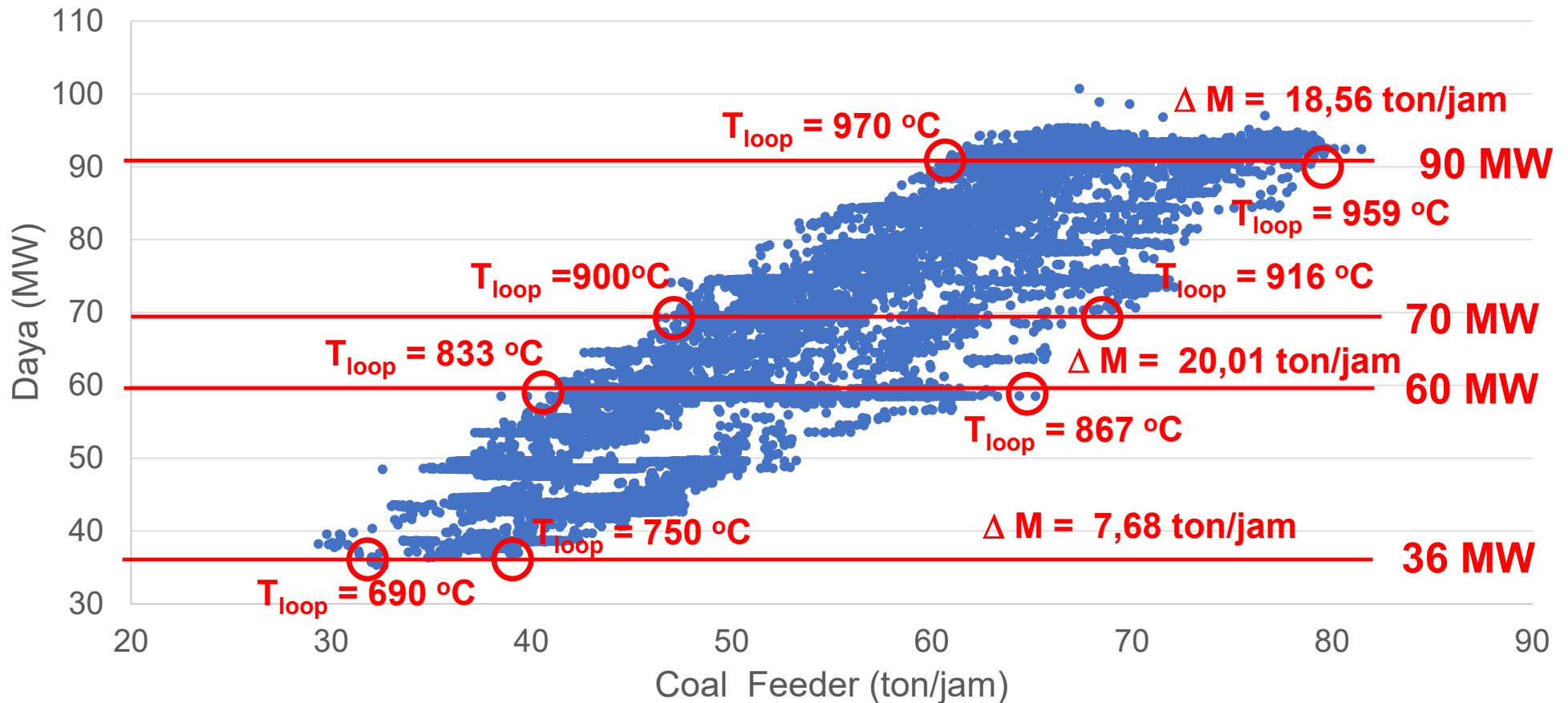

POTENSI PENGHEMATAN BATUBARA DAN PENGURANGAN EMISI CO2

DM	20,01	ton/jam			
Harga batubara per ton	50	US\$/ton			
Potensi penghematan	1000,5	US\$/jam			
	8.764.380	US\$/tahun			
Kurs Dollar terhadap rupiah	14800				
Potensi penghematan	129.712.824.000	Rupiah			
Asumsi kandungan C batubara	50	%-berat			
Jumlah C yang bisa direduce	10,005	ton/jam			
	C	+	O2	=	CO2
	0,83375		0,83375		0,83375
Potensi reduce CO2	36,685	ton/jam			
	316.958	ton/tahun			

PERMASALAHAN OPERASI CFB PLTU TELUK BALIKPAPAN

UKURAN
PARTIKEL
TERLALU BESAR

LAJU ALIR
UDARA
FLUIDISASI
KURANG

LAJU ALIR
UDARA
PEMBAKARAN
BERLEBIH

TERBENTUKNYA
HOT SPOT DI
AREA LOOP
SEAL

REKOMENDASI PENYELESAIAN MASALAH

PERBAIKAN
MENYELURUH
AREA CRUSHER

KALIBRASI O2
ANALYZER DAN
FAN (PA DAN SA)

PEMBESARAN
AREA LOOP SEAL

USULAN SKEMATIK SISTEM CRUSHER PLTU TELUK BALIKPAPAN

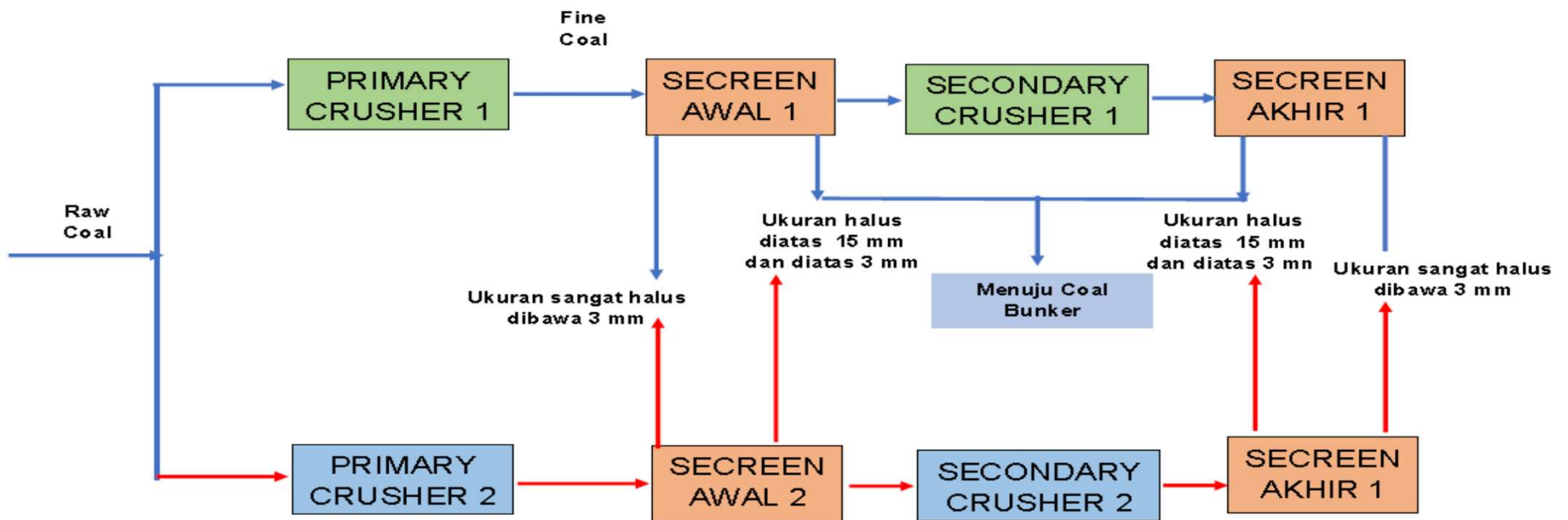

TAHAP 3

Profil Hidrodinamika Berdasarkan Literatur

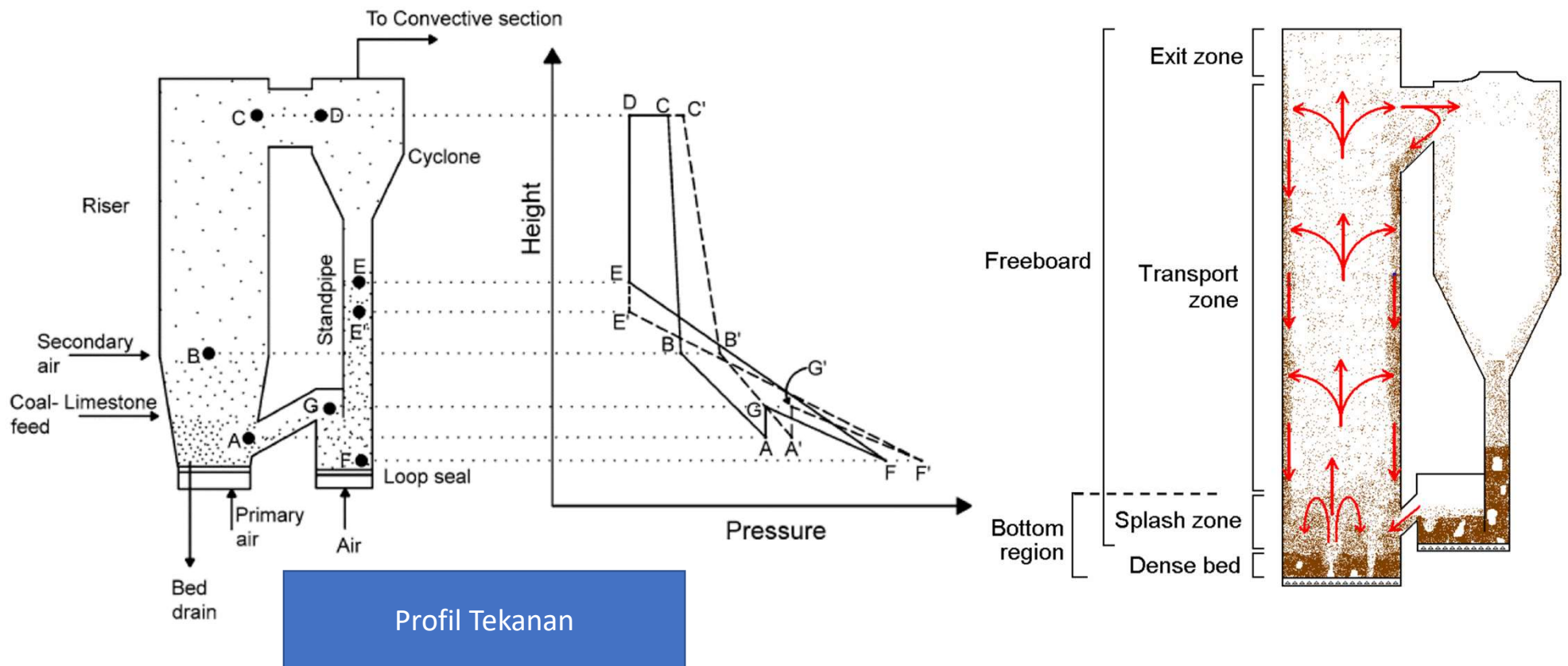

PRESSURE CYCLE IN CFB

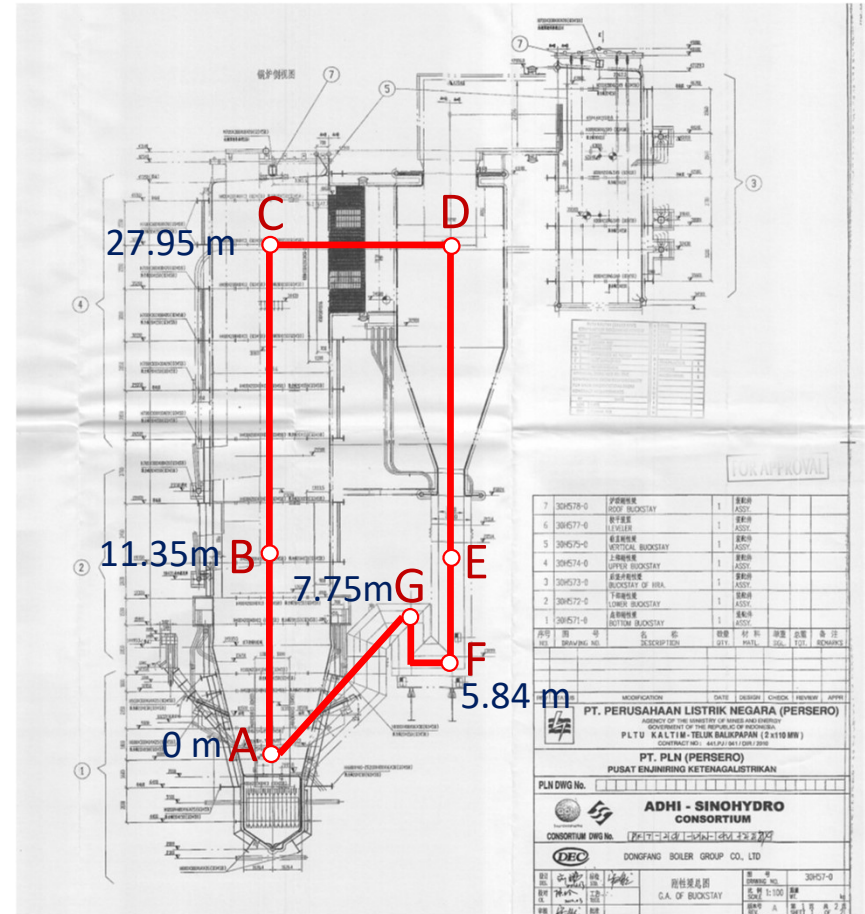
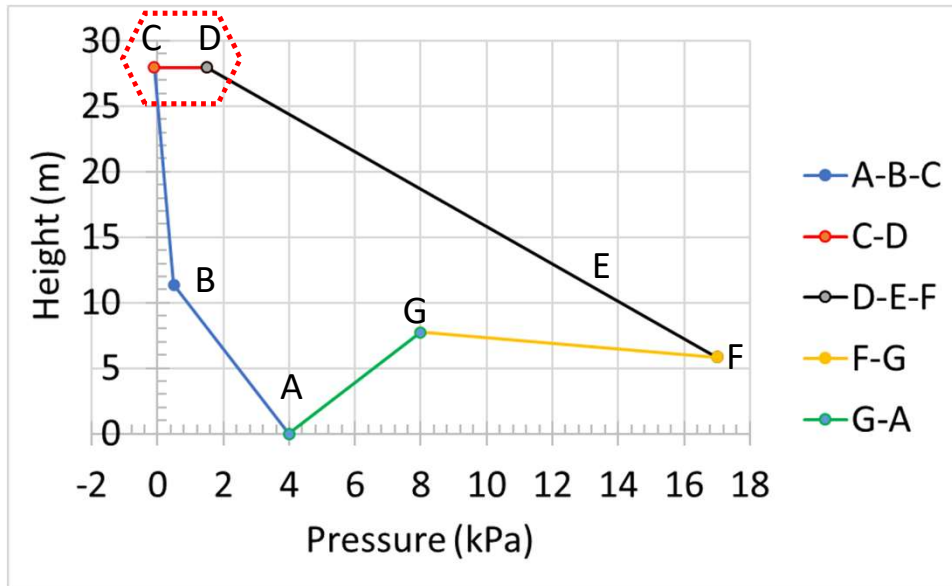

EVALUASI LOOP SEAL

Pengendalian Temperatur Loop Seal

Perbaiki sistem Instrumentasi untuk menjaga Keseimbangan Tekanan

Analisa Distribusi Komponen Pasir Silika dan Non Pasir Silika di Loop Seal System

Pengendalian Perbedaan tekanan Downcomer

Uji Dingin Hidrodinamika Padatan

TAHAP 4

Efisiensi

**PROKSIMAT ANALISIS (AR) UNTUK BATUBARA
YANG DIGUNAKAN UNTUK PERFORMANCE TEST
APRIL – JUNI 2021**

Parameter	April		Mei		Juni	
	I	II	I	II	I	II
Total Moisture (TM)	35,09	44,25	RSH	35,61	36,72	34,83
Volatile Matter (VM)	33,13	28,12		31,86	31,67	32,09
Fixed Carbon (FC)	27,98	23,64		27,70	26,03	27,61
Ash	3,80	3,98		4,82	5,58	5,47
Gross Calorific Value (kkal/kg)	4111	3358		4001	3671	3928

**ULTIMAT ANALISIS (AR) UNTUK BATUBARA
YANG DIGUNAKAN UNTUK PERFORMANCE TEST
APRIL – JUNI 2021**

Parameter	April		Mei		Juni	
	I	II	I	II	I	II
C	43,05	35,62	RSH	42,49	39,06	41,52
H	3,27	2,63		3,07	2,97	3,13
N	0,57	0,54		0,65	0,52	0,58
S	0,12	0,32		0,52	0,56	0,75
O	14,11	12,65		12,84	14,59	13,72
Air	35,09	44,25		35,61	36,72	34,83
Abu	3,80	3,98		4,82	5,58	5,47
Gross Calorific Value (kkal/kg)	4111	3358		4001	3671	3928

**LAJU ALIR BATUBARA, LAJU ALIR STEAM DAN BEBAN
YANG DIHASILKAN UNTUK PERFORMANCE TEST
APRIL – JUNI 2021**

Parameter	April		Mei		Juni	
	I	II	I	II	I	II
Gross Calorific Value (kkal/kg)	4111	3358	RSH	4001	3671	3928
Coal Flow (ton/jam)	70,3	84,1		67,6	94,7	72,6
Steam Flow (ton/jam)	362,3	363,5		366,32	353,6	364,4
Beban (MW)	99,50	100,13		99,99	98,7	99,71
NPHR	3303	3203		3089	4041	3261

Hubungan Efisiensi Termal Terhadap Kebutuhan Batubara (kg/jam) pada Berbagai Beban (MW) dengan kandungan kalor batubara = 4000 kkal/kg

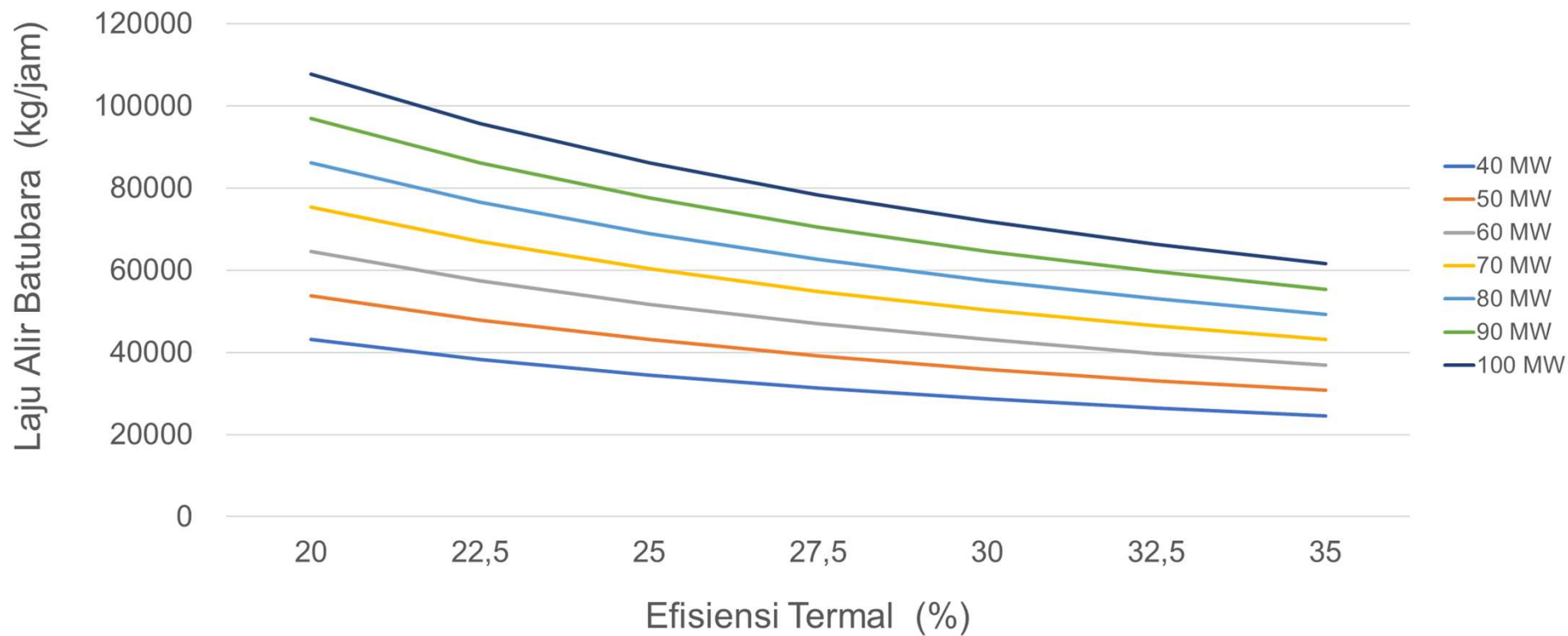

Hubungan antara laju alir udara Primer terhadap beban untuk berbagai efisiensi termal

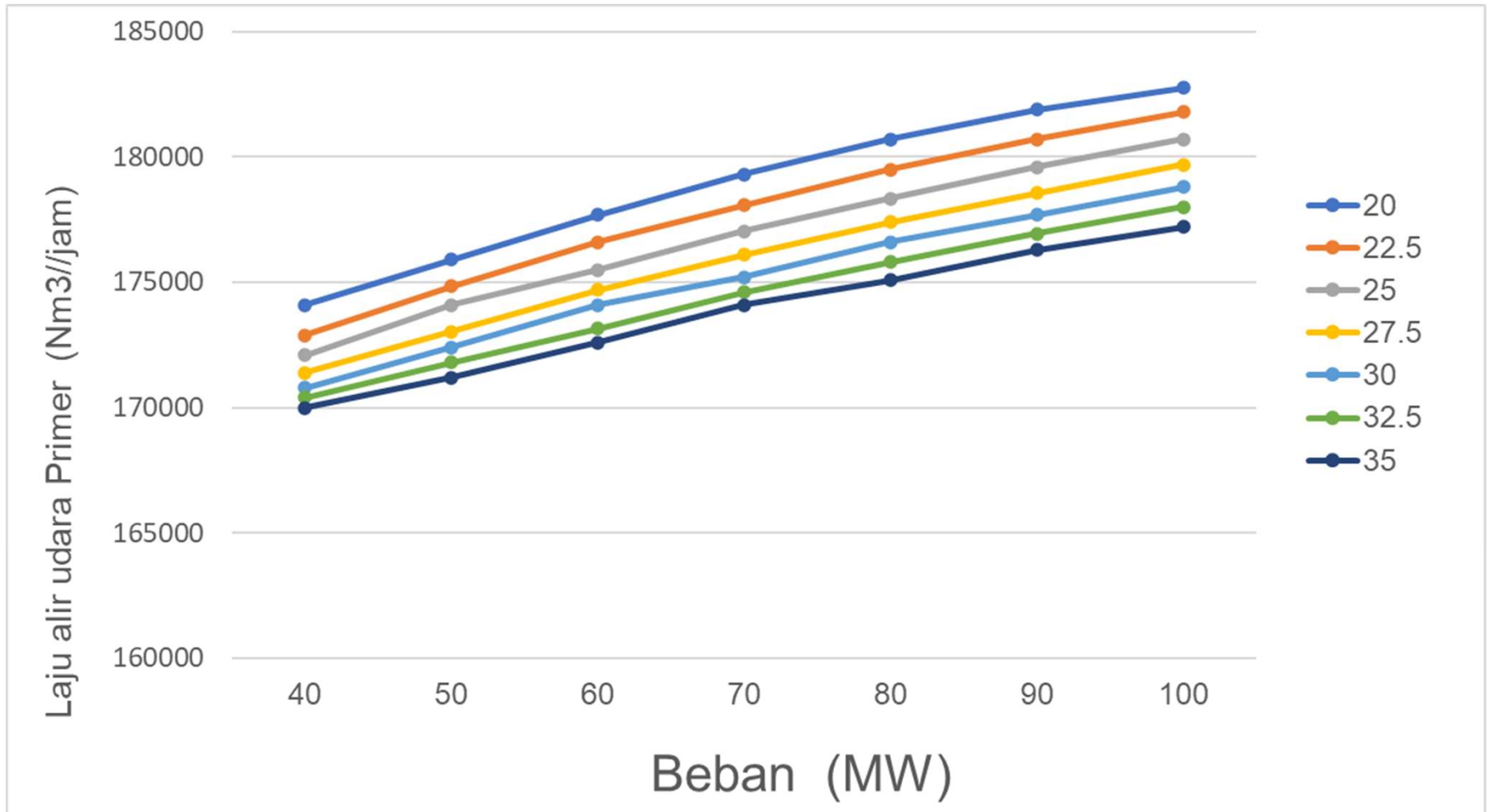

Analisa Efisiensi Pembangkit berdasarkan Data Laporan Efisiensi Bulanan PLTU Teluk

No	Parameter	April 2021		Mei 2021		Juni 2021	
		Unit 1	Unit 2	Unit 1	Unit 2	Unit 1	Unit 2
1	Power						
	Daya Gross [MW]	99.7	100.13	off	100.63	98.7	99.71
	Daya Nett [MW]	86.60	86.97		87.10	84.95	85.82
	Aux Power [kW]	9,519.81	9,525.97		9,606.25	9,511.86	9,509.46
	Aux Power Total [%]	13.14	13.14	off	13.45	13.93	13.93
	Aux Power Total [kW]	13,100.6	13,157.1		13,534.7	13,748.9	13,889.6
2	Coal						
	GCV (COA) [kcal/kg]	4,133.0	4,152.0		4,094.0	3,986.0	4,159.0
	GCV (Lab) [kcal/kg]	4,111.0	3,358.0		4,001.0	3,678.0	3,928.0
	MFR Coal [kg/hr]	70,820.0	85,223.0	off	68,641.8	97,340.0	73,092.5
3	Steam						
	MFR Steam [Ton/hr]	362.3	362.6		368.3	353.6	364.4
	To Turbine						
	Tekanan Steam 1 [Mpa]	8.94	8.91	off	9.51	8.87	8.82
	Tekanan Steam 2 [Mpa]	8.97	8.89	off	9.49	8.9	8.8
	Temperature Steam 1 [degC]	535.79	533.31	off	532.55	537.96	535.79
	Temperature Steam 2 [degC]	536.43	537.19	off	537.91	534.33	541.51
	Entalpi Steam 1 [kJ/kg]	3,475.93	3,470.10		3,461.81	3,482.03	3,477.19
	Entalpi Steam 2 [kJ/kg]	3,477.20	3,479.92		3,475.43	3,472.84	3,491.52
	From Condenser						
	Tekanan Air [Mpa]	12.9	12.9	off	10.57	9.62	9.92
	Temperature Air [degC]	228	228	off	230.51	227.34	229.31
	Entalpi Air [kJ/kg]	982.77	982.77		993.72	978.85	988.02
	Energi Penguapan Steam [kJ/hr]	903,271,505.7	901,905,495.4		908,998,283.6	885,123,033.6	907,054,276.8
4	Performance						
	NPHR (COA) [kcal/kWh]	3,379.92	4,068.46	0	3,226.58	4,567.30	3,542.18
	NPHR (Lab) [kcal/kWh]	3,361.93	3,290.44	0	3,153.28	4,214.38	3,345.44
	Efisiensi Termal (COA) [%]	25.5%	21.2%	0	26.7%	18.9%	24.3%
	Efisiensi Termal (Lab) [%]	25.6%	26.2%	0	27.3%	20.4%	25.7%
	Boiler Efisiensi [%]	74.2%	75.4%	0	79.2%	59.1%	75.6%
	Input data						
	calculated parameter						

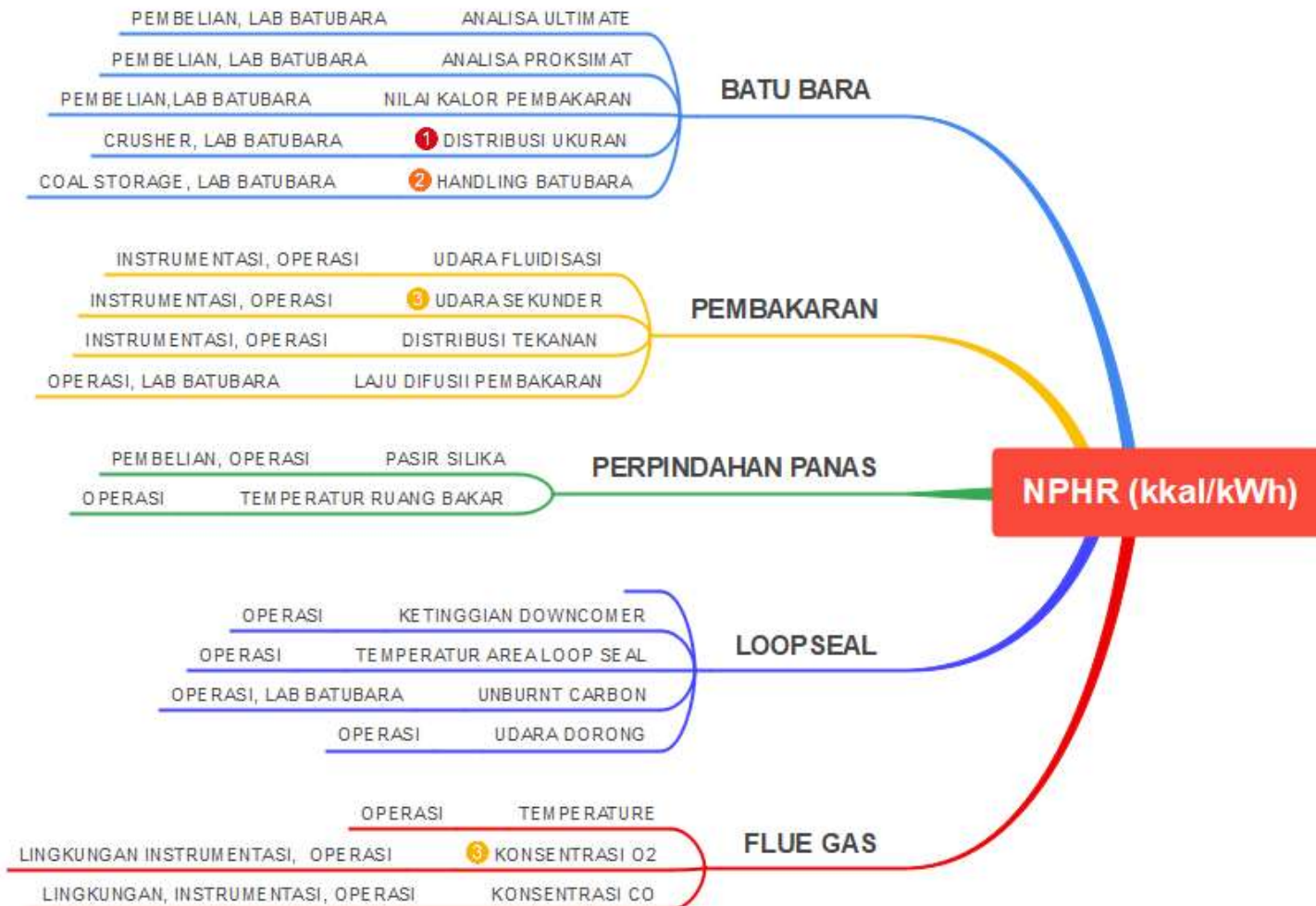

USULAN UNTUK PERBAIKAN SECARA KOMPREHENSIF UNTUK MENINGKATKAN KINERJA DARI PLTU TELUK BALIKPAPAN

NO	PARAMETER	PIC	KETERANGAN
1	Kualitas Batubara	Pembelian Batubara, Lab Batubara dan Operasi Boiler	Man (Operator dan Manajemen)
2	Handling Batubara	Operator Area Coal Stockyard, Lab Batubara	Man, Machine
3	Pengecilan Ukuran Batubara (Crusher)	Lab Batubara	Man, Machine
4	Pengendalian Udara Primer dan Sekunder	Operator Produksi dan Instrumentasi	Man
5	Pengendalian Area Loopseal	Operator Produksi dan Instrumentasi	Man
6	CO dan O2 Monitoring	Lingkungan, Operator Produksi, Instrumentasi	Man and Machine
7	Hydrodinamika dan Pembakaran	Operator Produksi, Instrumentasi	Man
8	Pressure Balance	Operator Produksi, Instrumentasi	Man
9	Kualitas Pasir Silika	Pembelian Pasir Silika dan Laboratorium, Operator Boiler	Man

TAHAP 5

Algoritma Program

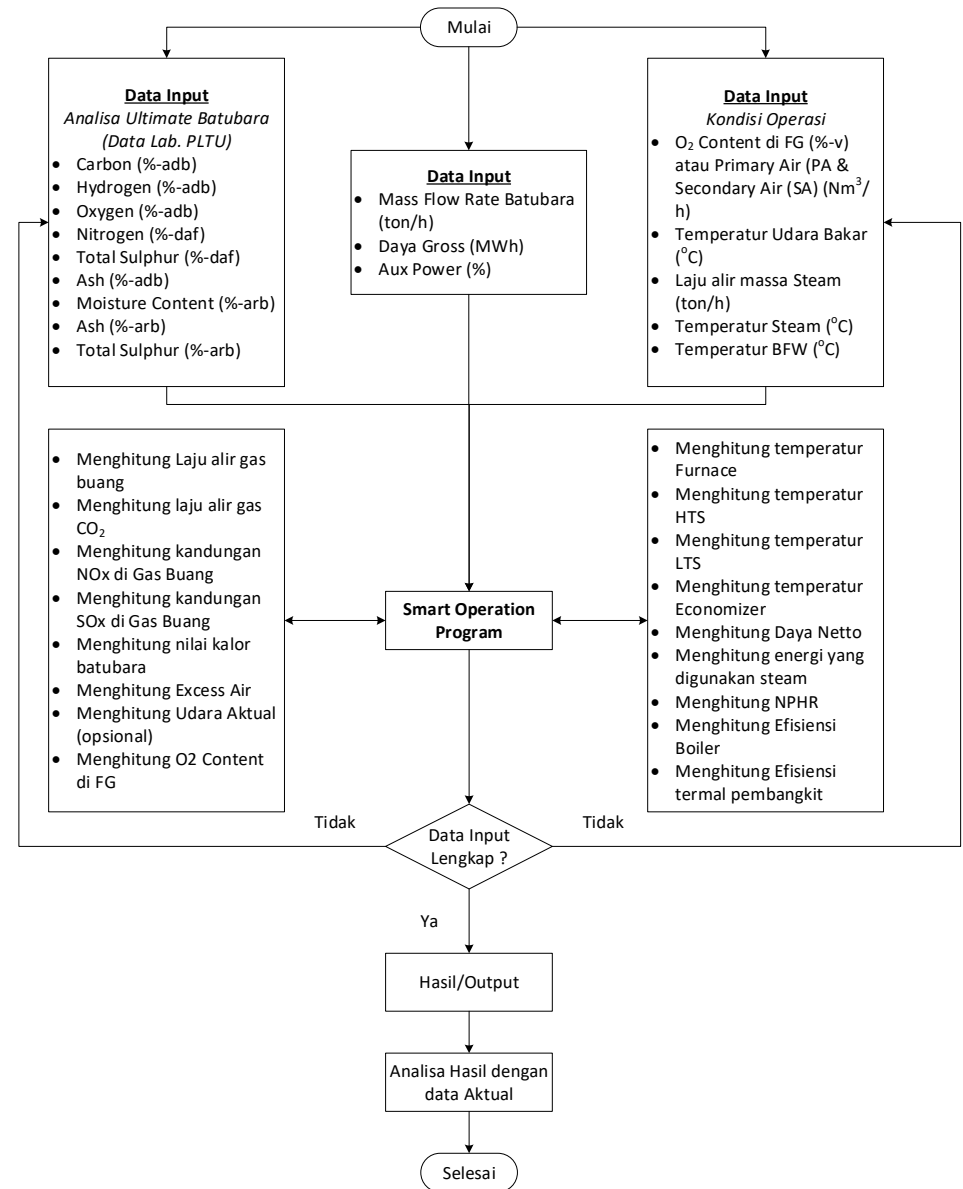

MEKANISME PERHITUNGAN – KONVERSI BASIS BATUBARA

Input

Analisa Ultimate Batubara Lab. PLTU

- ✓ Carbon (%-adb)
- ✓ Hydrogen (%-adb)
- ✓ Oxygen (%-adb)
- ✓ Nitrogen (%-daf)
- ✓ Total Sulphur (%-daf)
- ✓ Ash (%-adb)
- ✓ Moisture Content (%-arb)
- ✓ Ash (%-arb)
- ✓ Total Sulphur (%-arb)



**Program Smart
Operation
Boiler**



Output

Analisa Ultimate Batubara Hasil Konversi

- ✓ Carbon (%-arb)
- ✓ Hydrogen (%-arb)
- ✓ Oxygen (%-arb)
- ✓ Nitrogen (%-arb)
- ✓ Total Sulphur (%-arb)
- ✓ Ash (%-arb)
- ✓ Moisture Content (%-arb)

MEKANISME PERHITUNGAN – COAL BLENDING

Input *Analisa Ultimate Batubara Lab. PLTU*

- ✓ Carbon (%-arb)
- ✓ Hydrogen (%-arb)
- ✓ Oxygen (%-arb)
- ✓ Nitrogen (%-arb)
- ✓ Total Sulphur (%-arb)
- ✓ Ash (%-arb)
- ✓ Moisture Content (%-arb)
- ✓ Laju alir massa Batubara (ton/h)

Program Smart Operation Boiler

Output

Analisa Ultimate Batubara Campuran (Blending Coal)

- ✓ Carbon (%-arb)
- ✓ Hydrogen (%-arb)
- ✓ Oxygen (%-arb)
- ✓ Nitrogen (%-arb)
- ✓ Total Sulphur (%-arb)
- ✓ Ash (%-arb)
- ✓ Moisture Content (%-arb)
- ✓ Nilai kalor batubara Campuran (GCV) (kcal/kg)

- ✓ Menghitung komposisi batubara (C, H, O, N, S, MC, Ash) campuran melalui pers. Empiris
- ✓ Menghitung nilai kalor batubara campuran melalui pers. empiris

MEKANISME PERHITUNGAN - OPERASI

Input 1

Analisa Ultimate Batubara Lab. PLTU

- ✓ Carbon (%-adb)
- ✓ Hydrogen (%-adb)
- ✓ Oxygen (%-adb)
- ✓ Nitrogen (%-daf)
- ✓ Total Sulphur (%-daf)
- ✓ Ash (%-adb)
- ✓ Moisture Content (%-arb)
- ✓ Ash (%-arb)
- ✓ Total Sulphur (%-arb)

Input 2

Kondisi Operasi CFB

- ✓ O₂ Content di FG (%-v) atau Primary Air (PA & Secondary Air (SA) (Nm³/h)
- ✓ Temperatur Udara Bakar (°C)
- ✓ Laju alir massa Steam (ton/h)
 - ✓ Temperatur Steam (°C)
 - ✓ Temperatur BFW (°C)
- ✓ Mass Flow Rate Batubara (ton/h)
 - ✓ Daya Gross (MWh)
 - ✓ Aux Power (%)

Program Smart Operation Boiler

- ✓ Menghitung laju alir gas buang (CO₂, N₂, H₂O, SO_x, NO_x)
 - ✓ Menghitung excess air
 - ✓ Menghitung udara aktual (optional)
 - ✓ Menghitung O₂ content di FG (optional)
 - ✓ Menghitung nilai kalor batubara melalui pers. empiris
- ✓ Menghitung Temperatur furnace, HTS, LTS, dan economizer melalui pers. Empiris
- ✓ Menghitung entalpi penguapan melalui pers. Empiris
 - ✓ Menghitung nilai NPHR
 - ✓ Menghitung efisiensi boiler
- ✓ Menghitung efisiensi termal pembangkit

Output

- Jumlah Udara (Nm³/h)
- Excess Air (%)
- Laju alir Gas Buang (Nm³/s)
- Kadar SO_x di gas buang (mg/Nm³)
- Gas CO₂ di gas buang (%-v, db)
- O₂ content in FG (%) (optional)
- Nilai kalor batubara (GCV) (kcal/kg)
- Temperatur Furnace (Furnace in temp) (°C)
- Temp inlet HTS (°C)
- Temp inlet LTS (°C)
- Temp outlet Economizer (°C)
- NPHR (kcal/kWh)
- Efisiensi Termal Pembangkit (%)
- Efisiensi Boiler (%)
- Keterangan standar baku mutu emisi Sox dari Industri Pembangkit

TAHAP 5 DAN 6

CODE INSTRUMENTATION BOILER COMBUSTION SYSTEM UNIT 1 PLTU TELUK BALIKPAPAN

- PRESSURE
- TEMPERATURE
- CYCLONE B AREA

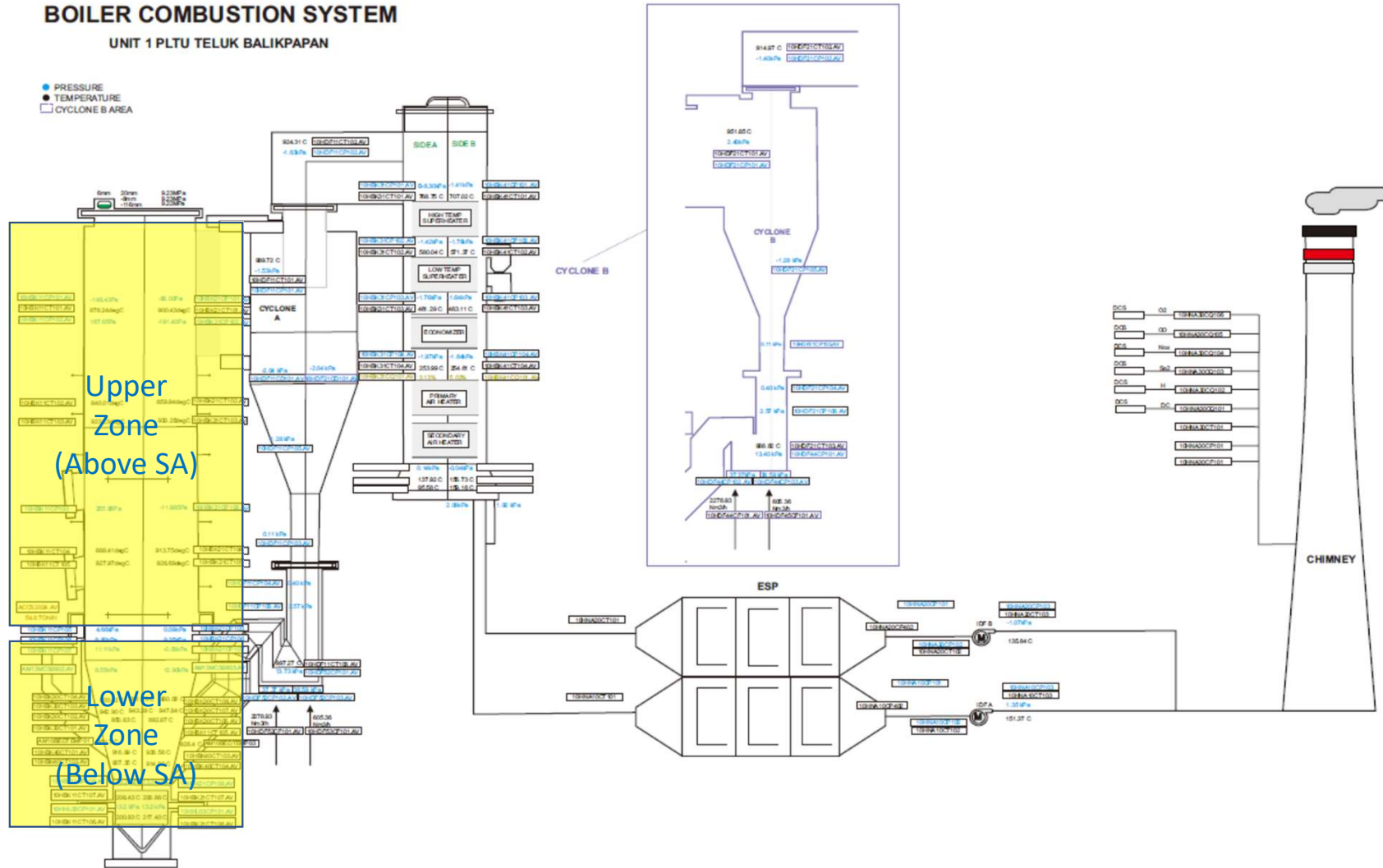

Mechanism of Coal

- Heating and drying (proses cepat 1-10 detik)
- Devolatilization and volatile combustion (proses cepat 1-10 detik)
- Burning of char (proses lambat > 100 detik)

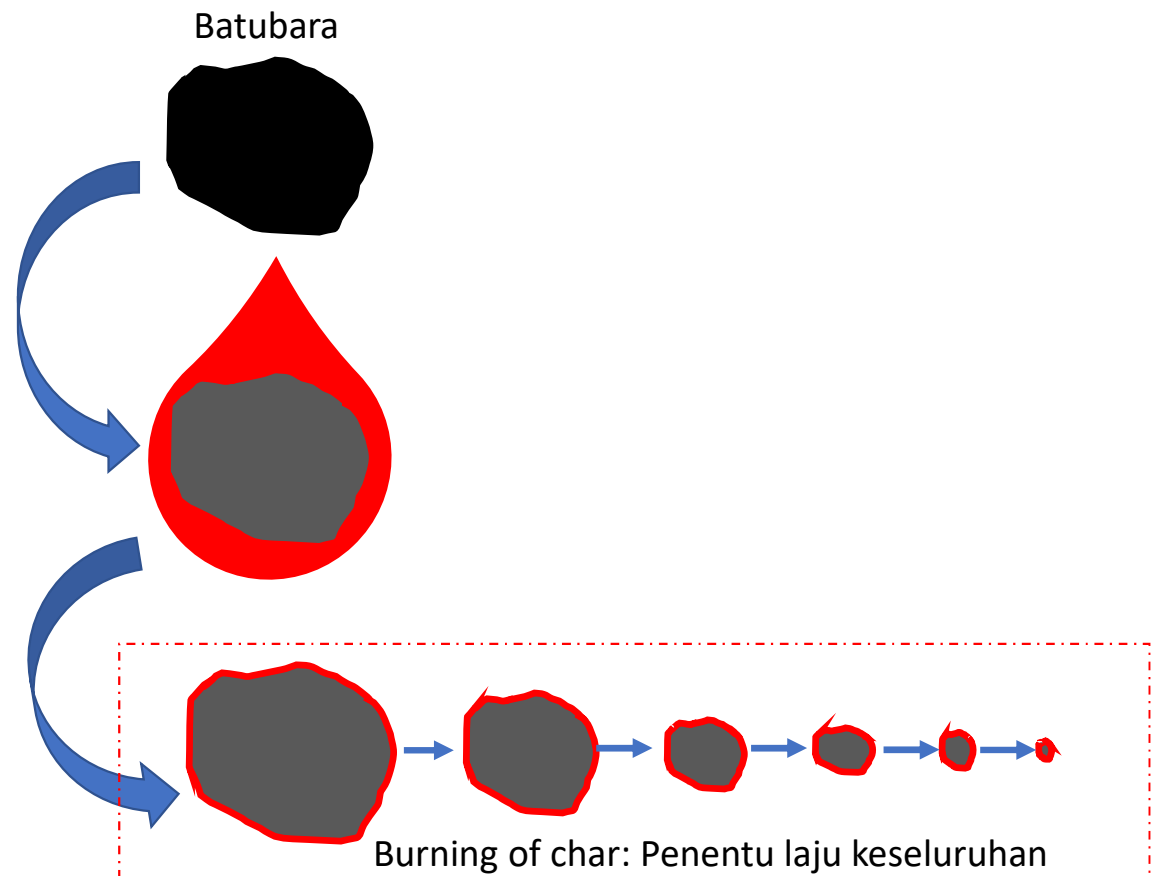

Zonasi

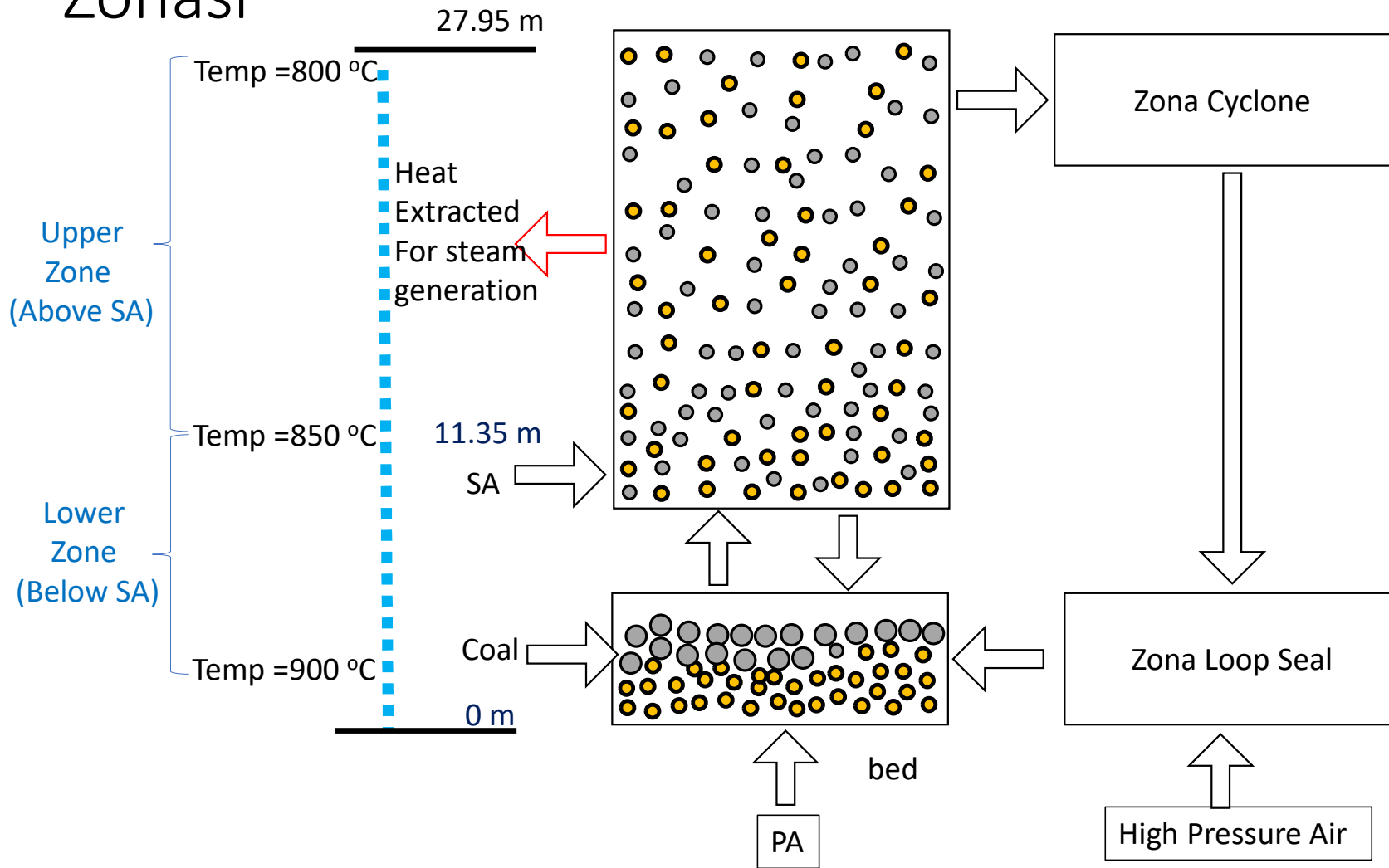

Model Matematik di Lower Zone

Pemanasan, pengeringan, devolatilisasi and pembakaran VM

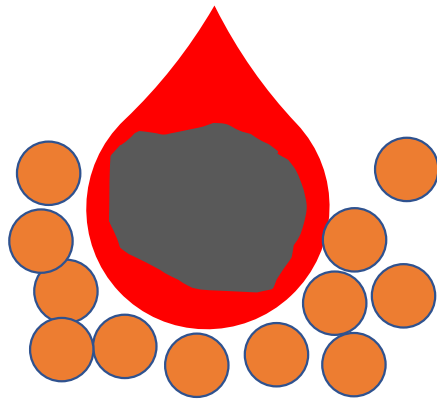

Neraca massa

$$\frac{dm}{dt} = (R_{comb})CgA$$

Neraca energi

$$mc_p \frac{dT_p}{dt} = (Q_{comb} + Q_{heating} + Q_{drying} + Q_{devolatilization})A - hA(T_p - T_b) - \varepsilon_p \sigma A(T_p^4 - T_b^4)$$

Sand for equation

$$Q_{comb} = (R_{comb})Cg\Delta H_c$$

R_{comb} = laju pembakaran karbon ($\text{kg m}^{-2} \text{s}^{-1} \text{kPa}^{-1}$)

Cg = konsentrasi oksigen dalam tekanan parsial (kPa)

Neraca Massa

Laju Pengurangan massa =
 Laju pengurangan massa karena reaksi pembakaran -
 Laju pengurangan massa karena proses fisika
 fragmentasi dan atrisi

$$\frac{dm}{dt} = -qA - k_a(U_c - U_p)A$$

$$q = \frac{C_g}{\left(\frac{1}{h_m} + \frac{1}{R_c}\right)}$$

C_g = tekanan parsial O_2 di fasa bulk

h_m = koefisien perpindahan massa ($\frac{kgC}{kmol}$)

$$R_c = 1.18 \exp\left(-\frac{8284}{T_p}\right)$$

k_a = konstanta atrisi termodifikasi ($kg\ m^{-3}$)

U_c = kecepatan rata-rata unggun naik ($m\ s^{-1}$)

U_p = kecepatan partikel ($m\ s^{-1}$)

Laju pengurangan massa karena pembakaran dan fragmentasi-atrisi

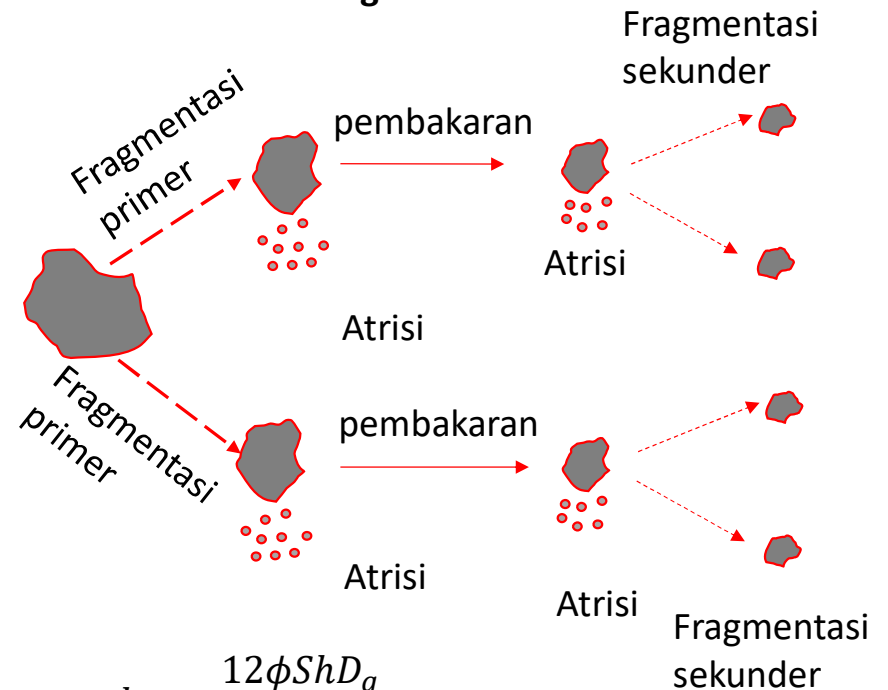

$$h_m = \frac{12\phi Sh D_g}{d_c R T_m}$$

ϕ = 1-2 (1 jika produk utama CO_2 , 2 jika produk utama CO)

D_g = difusivitas oksigen di gas (m^2/s)

d_c = diameter partikel

Neraca Momentum

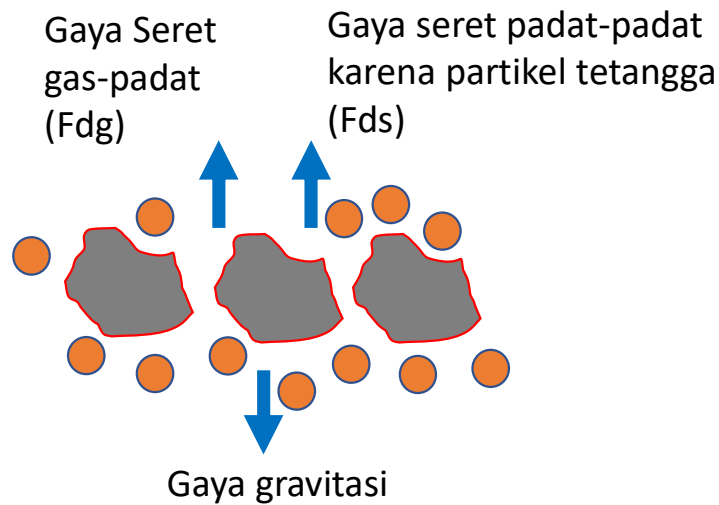

Gaya Seret gas-padat (Fdg)

$$F_{dg} = 0.75 \frac{C_d \rho_g (U_g - U_p)^2}{D_p}$$

$$C_d = \frac{24}{Re} (1 + 0.15 Re^{0.687})$$

Re < 1000

$$C_d = 0.44$$

Re > 1000

Gaya seret padat-padat karena partikel berdekatan (Fds)

$$F_{ds} = \frac{C_f \rho_s (1 - \varepsilon) (U_s - U_p)^2}{D_p}$$

$$C_f = 0.7 D_p^{-0.146}$$

$$U_s = U_g - U_{st}$$

Neraca momentum

$$\rho_p \frac{dU_p}{dt} = -\rho_g g + F_{dg} + F_{ds}$$

Neraca Energi

Laju akumulasi panas = laju panas reaksi - laju panas konveksi - laju panas radiasi

$$m c_p \frac{dT_p}{dt} = \eta q A \Delta H - h A (T_p - T_g) - \varepsilon_p \sigma A (T_p^4 - T_b^4)$$

Konstanta perpindahan panas konveksi (h) diperoleh dari rumus berikut

$$\frac{h D_p}{k} = 0.33 Re^{0.62} \left(\frac{d_p}{D_p} \right)^{-0.1}$$

$$Re = \frac{\rho_g D_p (U_g - U_p)}{\mu_g}$$

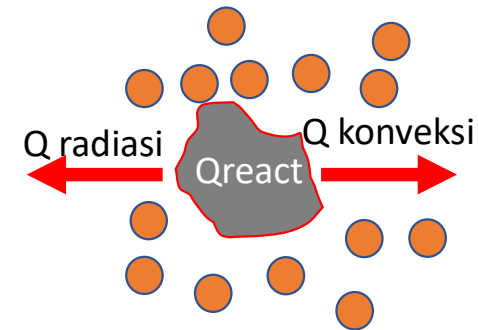

ΔH = panas pembakaran karbon (kJ/kg)

Model Matematik Upper Zone

Neraca massa	$\frac{dm}{dt} = -qA - k_a(U_c - U_p)A$
Neraca momentum	$\rho_p \frac{dU_p}{dt} = -\rho_g g + F_{dg} + F_{ds}$
Neraca energi	$mc_p \frac{dT_p}{dt} = \eta q A \Delta H - hA(T_p - T_b) - \varepsilon_p \sigma A(T_p^4 - T_b^4)$

Keterangan :

m = massa partikel (kg)

t = waktu (s)

q = laju pembakaran karbon ($\text{kg m}^{-2} \text{s}^{-1}$)

A = luas permukaan partikel karbon (m^2)

k_a = konstanta atrisi termodifikasi (kg m^{-3})

U_c = kecepatan rata-rata unggun naik (m s^{-1})

U_p = kecepatan partikel (m s^{-1})

T_p = Temperatur partikel (K)

T_b = Temperatur unggun (K)

Keterangan :

ρ_p = densitas partikel (kg m^{-3})

ρ_g = densitas gas (kg m^{-3})

F_{dg} = Gaya seret per unit volume ($\text{kg m}^{-2} \text{s}^{-2}$)

F_{ds} = gaya tarik menarik antar padatan per unit volume ($\text{kg m}^{-2} \text{s}^{-2}$)

η = factor efektivitas

h = koefisien perpindahan panas ($\text{kW m}^{-2} \text{K}^{-1}$)

ΔH = panas yang dihasilkan dari pembakaran karbon (kJ/kg)

ε_p = emisivitas partikel karbon

σ = konstanta Stefan Boltzman ($5.67 \times 10^{-8} \text{ W m}^{-2} \text{ K}^{-4}$)

TAHAP 6



**EVALUASI
PARTICLE SIZE DISTRIBUTION (PSD)
BATUBARA
PLTU TELUK BALIKPAPAN**

DATA DISTRIBUSI UKURAN UNTUK INLET CRUSHER (mm)

Bulan	Tanggal	Jam	Distribusi Ukuran Inlet Crusher (mm)					
			+ 50	- 50 + 22,4	-22 + 16	- 16 + 11,2	11,2 + 4,75	- 4,75
April	12/04/2021	13.50-16.50	2,23	33,82	11,91	10,71	15,93	25,39
Mei	31/05/2021	11.50-12.30	28,89	27,93	7,10	6,87	10,97	18,25
Juni	09/06/2021	10.27-11.03	18,36	43	7,48	6,09	7,93	17,14
	15/06/2021	13.30-12.30	12,66	30,05	10,28	9,22	14,41	23,38
	16/06/2021	21.40-22.16	16,46	34,18	7,01	4,31	5,51	32,54
	17/06/2021	15.00-15.40						
	28/06/2021	14,45	29,19	27,23	7,11	6,18	9,92	20,36
Agustus	09/08/2021	10,2	48,71	19,97	6,73	5,24	8,00	11,40
	29/08/2021	11	34,55	25,81	5,92	5,02	8,95	19,75
September	06/09/2021	11:00:00 AM	5,93	29,51	11,55	11,24	16,80	24,98
	16/09/2021	11,5	32,55	39,68	6,76	4,77	6,18	10,06
	29/09/2021	14:00:00 AM	27,13	54,69	6,78	3,71	3,57	4,13

DATA DISTRIBUSI UKURAN UNTUK OUTLET CRUSHER (mm)

Bulan	Distribusi Ukuran Outlet Crusher (mm)					
	+ 50	- 50 + 22,4	-22 + 16	- 16 + 11,2	11,2 + 4,75	- 4,75
April						
Mei	8,14	37,02	11,29	9,89	14,60	19,07
Juni	13,67	45,49	10,27	7,53	9,88	13,17
	0,17	10,52	9,62	12,29	22,12	45,27
	1,19	29,30	12,21	12,48	21,85	22,96
	1,52	35,83	11,28	10,86	14,94	25,58
Agustus	0,85	28,04	11,86	11,37	18,15	29,73
	0,00	9,79	15,32	14,65	21,58	38,66
September	0,00	7,43	14,19	13,57	23,30	41,51
	6,06	32,07	12,34	10,00	15,28	24,25
	18,82	50,77	11,72	7,34	6,79	4,57

HISTOGRAM DISTRIBUSI UKURAN UNTUK OUTLET CRUSHER (mm)

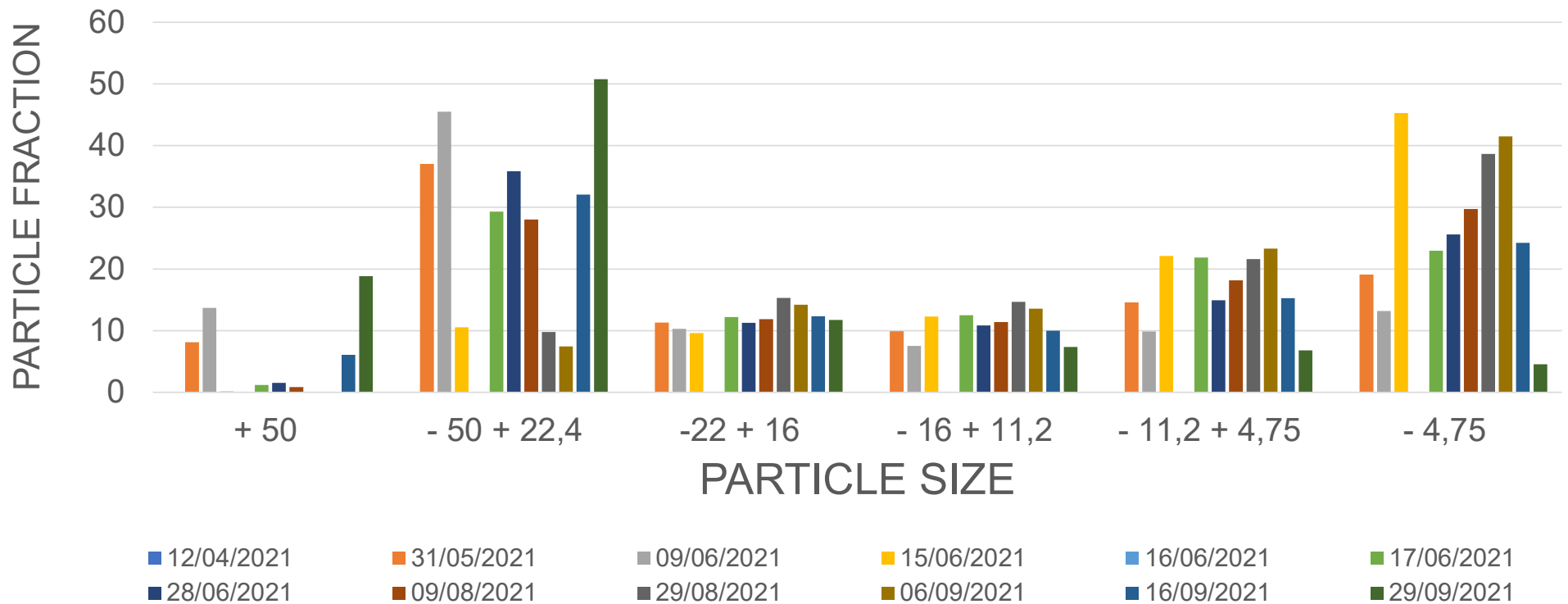

UKURAN RATA-RATA PARTIKEL BATUBARA SEBELUM DAN SESUDAH MASUK CRUSHER (mm)

Waktu	mean diameter (dp), mm	
	inlet	outlet
31/05/2021	28,14	22,58
09/06/2021	28,03	27,38
15/06/2021	22,12	10,23
28/06/2021	27,92	19,15
09/08/2021	34,47	16,53
29/08/2021	29,61	11,09
06/09/2021	19,30	10,08
16/09/2021	33,30	20,14
29/09/2021	35,54	31,66

CAUSAL EFFECT DARI UKURAN BATUBARA UNTUK PEMBAKARAN DI
CFB PLTU TELUK BALIKPAPAN YANG TIDAK SESUAI



REKOMENDASI SISTEM CRUSHER

1. Unjuk Kerja Crusher Eksisting telah dilakukan dengan pengambilan sampel pada saat masuk dan keluar dengan menggunakan screen analyzer di laboratorium batubara
2. Peralatan Crusher harus memiliki screen untuk mengetahui kualitas produk yang dihasilkan
3. Crusher harus mampu menghancurkan semua batubara yang masuk ke PLTU Teluk Balikpapan pada rentang HGI yang dipersyaratkan
4. Crusher yang tersedia harus memiliki **Reliability dan Endurance** yang bagus sehingga perlu dipasang crusher series dengan adanya cadangan serta dilengkapi screen

USULAN SKEMATIK SISTEM CRUSHER PLTU TELUK BALIKPAPAN

