

PAPER • OPEN ACCESS

Expanded Coverage Remote Control

To cite this article: Hadian Satria Utama *et al* 2020 *IOP Conf. Ser.: Mater. Sci. Eng.* **852** 012155

View the [article online](#) for updates and enhancements.

Expanded Coverage Remote Control

Hadian Satria Utama^{1*}, Tryas Honorris², Indra Surjati³

¹Department Electrical of Engineering, Faculty of Engineering,
Universitas Tarumanagara

²Department Electrical of Engineering, Faculty of Engineering,
Universitas Tarumanagara

³Graduate Program of Electrical Engineering, Faculty of Industrial and
Technology, Universitas Trisakti

* hadianu@ft.untar.ac.id

Abstract. Remote control mostly uses infrared radiation for transmitting data to be received by the controlled electronic home appliances. Since infrared radiation transmission is line of sight by nature, it is not effective when the control is needed for larger coverage areas where there are obstructions between transmitter and receiver. This limitation inspired the design of the expanded coverage remote controller. In this design, Android application is used for user interface. The application uses internet for data transmission media, so that controlling from different rooms or very long distances can be achieved. The controller was designed for five infrared control signals. The electronic home appliances that can be controlled are air conditioners and television sets, using preset buttons on the application.

1. Introduction

A remote control is an electronic device used to operate another device from a distance, usually wirelessly [1]. Remote controls available nowadays mostly uses infrared radiation for transmitting data wirelessly. Infrared radiation (IR), sometimes called infrared light, is electromagnetic radiation (EMR) with wavelengths longer than those of visible light, the red light [2]. Infrared has a disadvantage of not being able to go through non transparent material, therefore, if it is obstructed by an object then then the signal will be blocked and will not reach the desired destination.

The usage of infrared remote control is limited by the line of sight distance between the remote control and the electronic device to be controlled. The transmitter and the receiver of the signal have to face and be able to see each other without obstruction between them [3]. It happens very often that the electronic device to be controlled has a quite large distance from the remote control, so the user to bring the remote control closer and in the same room with the electronic device to be controlled, without any obstruction between the remote and the controlled electronic device. One of common electronic devices controlled using a remote control is a television set. Another problem is there are so many electronic devices to be controlled and they are in different rooms, wasting user's time and energy to do all those.

2. Design

The device consists of an infrared transceiver module and a smartphone application module. It is to be used for controlling two devices, an air conditioner and a television set. Therefore, the use of two different transceiver modules is needed.



The transceiver module receives infrared signal from the original remote control, sends infrared signal to the device to be controlled, sends data to the Internet, receives data from the Internet, monitors the status of the device to be controlled, and lights up LED indicators. The infrared receiver sensor receives infrared signal to be stored and processed by the microcontroller. After receiving the infrared signal, the microcontroller starts waiting for instructions from the user using a smartphone through the Internet. As soon as the instruction from the user is received, the transceiver sends the infrared signal desired by the user, which codes has been stored previously in the microcontroller memory.

The microcontroller sends the selected infrared signal then it receives the on/off status of the controlled device. This data is sent by the microcontroller through the Internet to the smartphone. The smartphone has an indicator that shows whether the device has been turned on or not yet.

The block diagram of the design is shown in Figure 1 and the designed system has the following specifications:

1. Uses 220V AC input voltage.
2. Uses Keyes KY-005 infrared transmitter module (37.9 kHz) dan Keyes KY-022 infrared receiver module (38 kHz) for infrared signal transmitter and receiver.
3. Uses LDR GL5539 for detecting light produced by electronic devices to be controlled.
4. Uses Wemos D1 mini microcontroller as the main controller of the system.

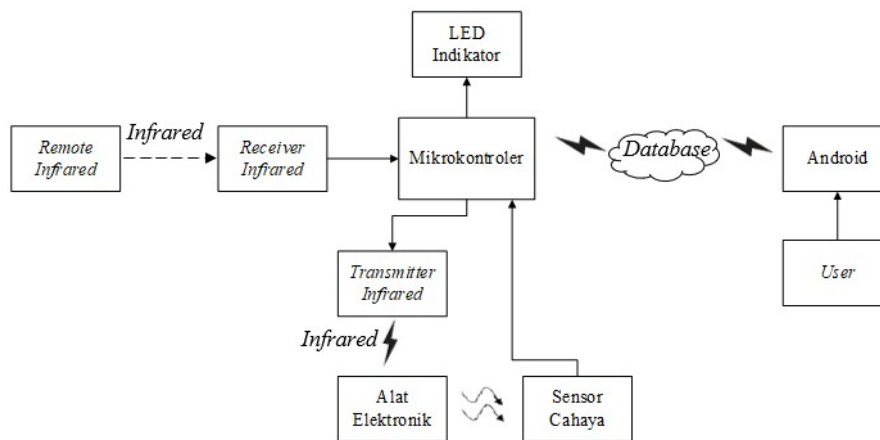

Figure 1. Block Diagram of the Designed System

A light dependent resistor (LDR) used to read the status of the controlled electronic devices. The output of the LDR is connected to the microcontroller through the analog pin (A0) of the Wemos D1 mini.

The microcontroller used has a built-in Wi-Fi module. For connecting to the internet and Firebase realtime database. The program segment for connecting microcontroller to the Firebase database server is shown in Figure 2.

```

// connect to wifi.
WiFi.begin(WIFI_SSID, WIFI_PASSWORD);
Serial.print("connecting");
while (WiFi.status() != WL_CONNECTED) {
  Serial.print(".");
  delay(500);

  digitalWrite(LED_WIFI, HIGH);
  delay(1000);
  digitalWrite(LED_WIFI, LOW);
  delay(1000);
}
Serial.println();
Serial.print("connected: ");
Serial.println(WiFi.localIP());

Firebase.begin(FIREBASE_HOST, FIREBASE_AUTH);

```

Figure 2. Potongan Program Pemroses Data ke Firebase

Program is started by entering the SSID name and the password of the Wi-Fi to be used, then the microcontroller will try to connect to the Wi-Fi. An LED indicator will show whether it is connected to the internet or not yet. The LED blinks if it is still not connected.



Figure 3. A Firebase Realtime Database data for AC and TV

After it is connected to the Internet, in this case the Firebase database, the LED light up completely (stop blinking). This design uses Firebase realtime database. Since there are two electronic devices, two database are needed, an example is shown in Figure 3.

The Android application was developed using MIT App Inventor for providing user with a user interface. The application user interface display is shown in Figure 4. User sent five infrared signals to the transceiver module. Every time the module successfully receives the infrared signal the LED indicator will blink once. After the microcontroller has received five signals, the LED will stop blinking. After this process is finished, both LED indicators light up completely. The finished system designed is shown in Figure 5.

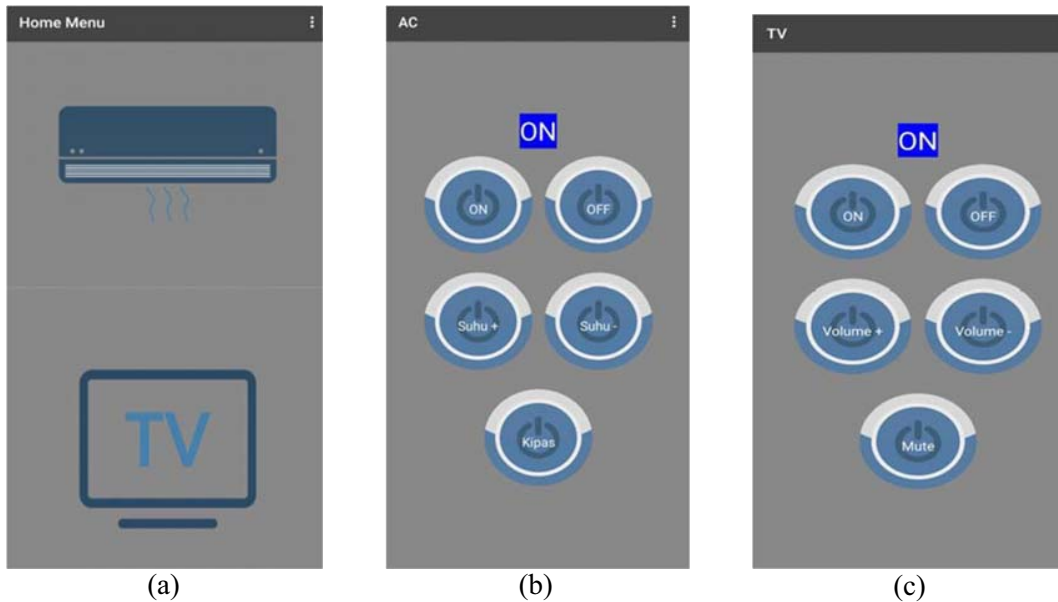
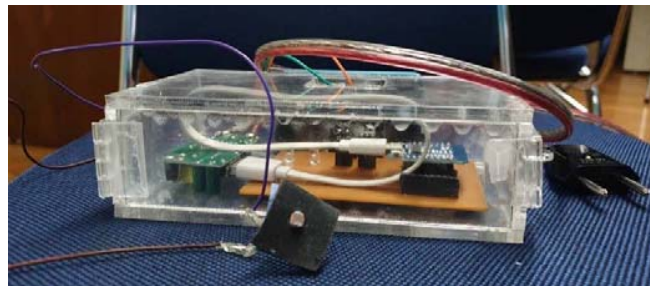

Figure 4. Application User Interface display for (a) Home Menu, (b) AC, and (c) TV



Gambar 5. Finished System

3. Test Results

The test result shown in this article is the test result of most important part which is the test for the infrared receiver. It is started by connecting receiver dan transmitter infrared module to the Wemos D1 mini microcontroller. First a program for reading the infrared signal transmitted from the infrared remote control is run in the microcontroller. The data can be observed at the *Serial Monitor* part of the ArduinoIDE application. The buttons used are the on and off buttons. The result is shown in Table 4.1.

Table 1. Infrared Receiver Test Result for the ON Button

Tombol	Kode
ON	Raw Timing[135]:
	+ 4494, - 4466, + 544, - 1686, + 542, - 1684, + 544, - 1684,
	+ 546, - 570, + 542, - 572, + 542, - 572, + 542, - 570,
	+ 542, - 574, + 540, - 1684, + 544, - 1684, + 546, - 1682,
	+ 546, - 570, + 592, - 522, + 544, - 570, + 542, - 570,
	+ 544, - 570, + 542, - 574, + 540, - 1686, + 544, - 570,
	+ 540, - 578, + 538, - 572, + 544, - 572, + 544, - 568,
	+ 544, - 570, + 594, - 1636, + 542, - 570, + 544, - 1684,
	+ 544, - 1684, + 544, - 1684, + 592, - 1620, + 562, - 1666,
	+ 560, - 1686, + 590, - 46736, + 4474, - 4468, + 590, - 1640,
	+ 588, - 1622, + 560, - 1686, + 592, - 548, + 512, - 600,
	+ 568, - 524, + 588, - 524, + 586, - 550, + 564, - 1666,
	+ 514, - 1690, + 592, - 1636, + 586, - 552, + 568, - 520,
	+ 590, - 548, + 566, - 550, + 516, - 598, + 566, - 548,
	+ 568, - 1636, + 592, - 546, + 562, - 552, + 562, - 550,
	+ 568, - 546, + 564, - 550, + 518, - 596, + 518, - 1686,
	+ 596, - 544, + 564, - 1640, + 542, - 1686, + 592, - 1636,
	+ 540, - 1708, + 572, - 1638, + 588, - 1664, + 516

Table 2. Infrared Receiver Test Result for the OFF Button

Tombol	Kode
OFF	Raw Timing[135]:
	+ 4522, - 4420, + 586, - 1644, + 542, - 1712, + 514, - 1688,
	+ 540, - 574, + 584, - 552, + 518, - 596, + 516, - 598,
	+ 516, - 600, + 564, - 1638, + 592, - 1640, + 540, - 1690,
	+ 536, - 598, + 566, - 548, + 516, - 598, + 568, - 546,
	+ 516, - 598, + 518, - 596, + 514, - 1688, + 590, - 530,
	+ 538, - 576, + 538, - 576, + 584, - 550, + 518, - 572,
	+ 592, - 524, + 538, - 1712, + 518, - 574, + 554, - 1668,
	+ 546, - 1686, + 544, - 1702, + 526, - 1670, + 608, - 1620,
	+ 560, - 1710, + 518, - 46784, + 4450, - 4478, + 560, - 1670,
	+ 608, - 1640, + 540, - 1684, + 546, - 570, + 542, - 574,
	+ 542, - 570, + 544, - 568, + 542, - 574, + 540, - 1684,
	+ 542, - 1686, + 546, - 1682, + 546, - 596, + 516, - 572,
	+ 542, - 572, + 540, - 580, + 538, - 574, + 540, - 572,
	+ 540, - 1686, + 544, - 572, + 542, - 568, + 542, - 576,
	+ 542, - 572, + 540, - 574, + 538, - 578, + 536, - 1688,
	+ 544, - 574, + 538, - 1690, + 540, - 1690, + 540, - 1688,
	+ 540, - 1688, + 540, - 1690, + 540, - 1686, + 540

4. Conclusion

Based on the result of the test performed on all modules and the overall system test, we can conclude that:

1. The objective of this design that is expanding the coverage of the original infrared remote control is successful.
2. The new coverage area is limited only by the Internet connection coverage.
3. The system can be expanded to be used for more than 2 devices.

5. References

- [1] W.E. Seiter, *Remote Control*, London: Routledge, pp. 2, 2013.
- [2] S.F. Vignola, *Solar and Infrared Radiation Measurements*, Boca Raton: CRC Press, pp. 205, 2012.
- [3] M.R. Robinson, *Night vision : Exploring The Infrared Universe*. Cambridge University Press, pp. 3, 2013.

- [4] F.D. Rumagit, "Perancangan Sistem Switching 16 Lampu Secara Nirkabel Menggunakan *Remote Control*," Jurnal Teknik Elektro Dan Komputer Unsrat, vol. 1, pp. 1-5, 2012.
- [5] N. Lestari, "Alat Pengontrol Peralatan Menggunakan Remote Sensor Infra Merah Berbasis Mikrokontroler," Jurnal Teknologi Informasi Mura STMIK MUSIRAWAS, vol. 4, pp. 50-57, 2012.
- [6] F.P. Rahmiati, "Implementasi Sistem *Bluetooth* menggunakan Android dan Arduino untuk Kendali Peralatan Elektronik," Jurnal ELKOMIKA Itenas, vol. 2, pp. 1-14, 2014.
- [7] "Resistorguide," 19/04/2018. [Online]. Available: <http://www.resistorguide.com/photoresistor/>. [Accessed 23 April 2019, Pukul 21:53].
- [8] I.C.Melalolin, "Rancang Bangun Brankas Pengaman Otomatis Berbasis Mikrokontroler AT89S52," *Universitas Komputer Indonesia, Jurnal TELEKONTRAN*, vol. 1, pp. 59-66, 2013.