

**Tarumanagara International Conference
on the Applications of Technology and Engineering 2020**

CERTIFICATE
OF ACHIEVEMENT

Hugeng Hugeng

for the contribution as
ORAL PRESENTER

Paper Title

Implementation of an Automatic Secured Gas Stove Using Internet-of-Things Technology

August 3rd - 4th, 2020 | Universitas Tarumanagara, Jakarta

Chairman



Dr. Hugeng, S.T., M.T.

Rector



Prof. Dr. Ir. Agustinus Purna Irawan

PAPER • OPEN ACCESS

Implementation of an automatic secured gas stove using internet-of-things technology

To cite this article: Hugeng Hugeng *et al* 2020 *IOP Conf. Ser.: Mater. Sci. Eng.* **1007** 012195

View the [article online](#) for updates and enhancements.

Implementation of an automatic secured gas stove using internet-of-things technology

Hugeng Hugeng^{*1}, Steven Sulaiman¹, and Nurwijayanti K N²

¹Electrical Engineering Department, Universitas Tarumanagara, Jl. Letjen S. Parman No. 1, Jakarta 11440, Indonesia.

²Electrical Engineering Department, Universitas Suryadarma, Jl. Protokol Halim Perdanakusuma, Jakarta 13610, Indonesia

*corresponding author: hugeng@ft.untar.ac.id

Abstract. It was noted that the existence of house fires caused by gas stoves is still large. Gas stoves are common devices in Indonesian household. However, they have some drawbacks that can cause house fires. This causes the need for technological improvements in gas stoves to minimize this possibility. The implemented secured automatic gas stove uses a gas solenoid valve to automatically turn it on/off and can be monitored through an Android smartphone using Wi-Fi transmission, i.e. based on the Internet of Things, which is a value-added solution to gas stoves. The system also has a motion sensor to minimize the occurrence of negligence when cooking. This information will be sent and displayed on the Android application of user's smartphone. Warning will be given through the application so that user can act properly and immediately when getting it. Testing results were as follows. At first, the gas sensor could detect gas leak if it had passed the value of 300 ppm. Second, Android application could display information about the status whether gas stove turned on or off, and it could be turned off by pressing a button on it. At last, solenoid valve was successful in stopping the flow of gas from the gas cylinder. All functions of the overall system could work well as expected in the design stage.

1. Introduction

Technological developments make it easier to carry out various daily activities in life. Technology can be applied to various activities such as cooking in the household [1-3]. The use of a secured system for the cooking process with a gas stove is deemed necessary in order to increase safety when using a gas stove. Many researches have been carried out to improve the safety of gas stoves in general, such as the design of an automatic control system for conventional Liquefied Petroleum (LP) gas stoves in the Arduino Uno-based water boiling process [4] and the safety of gas stoves in particular, such as the design of a gas stove control system using an Android-based Arduino [5].

In today's digital era, the use of the internet has become commonplace for many people to meet various needs. Control via Android smartphones and computers using the internet or often referred to as the Internet of Things (IoT) is a technology that uses the internet as a means of doing something. As IoT develops, the use of IoT is expected to be combined with related technologies and concepts such as cloud computing, e-learning, big data.



Based on the background and problems discussed above, an automatic secured gas stove was designed. The condition of the designed gas stove can be monitored via a smartphone based on the technology of IoT. Wi-Fi is used to make an internet connection on a device designed so that the IoT can help provide real-time information to stove users via smartphones. The users can get information about their gas stoves when it is on or off, thus providing increased security during the cooking process and reduce the chance of house fires. The purpose of the system designed is to create an automatic secured system on a gas stove that uses IoT technology through an application on an Android smartphone and it shows the cooker the condition of the gas stove is whether on or off.

2. State-of-the-art

Many similar researches had been done before. This section aims to compare existing or built systems with our designed system. The first work was found in the form of a scientific paper entitled "Automatic Safety of One Furnace LP gas Stove Based on ATmega 16 Microcontroller" [3]. From their results, the security device would control the entry of gas to the gas stove and the active time of the lighter. The temperature sensor and gas sensor are input on the microcontroller to control the entry of gas to the stove. The limit switch sensor is placed on the gas knob valve as a microcontroller input signal to control the ignition of the lighter, so that the LP gas that comes out of the combustion furnace immediately burns because it coincides with the ignition of the lighter. The timer switch is also an input on the microcontroller to control the flow of LP gas to the stove through the control of the solenoid valve. At the beginning of the process, the microcontroller starts up by scanning the sensor from a danger state for 10 seconds, the stove will not turn on even though the valve on the gas knob opens. After 10 seconds, the sensor does not detect the gas leaking and excess heat, the microcontroller activates the solenoid valve so that the gas in the tube flows from the regulator to the gas knob valve, so the stove would turn on.

The second work was performed by a gas stove manufacturer, named Covina, with the website page <http://www.covina.co.id/product/komporgas-covina-cp-351-xx> and accessed on 17 March 2019 at 19.15 [6]. Their secured product was named Gas Stove Covina CP-351 XX. The Covina CP-351 XX Gas Stove is a gas stove that is equipped with a timer system that can be adjusted to the user's time requirements and can automatically turn off the stove when the timer is set for the time to be finished.

3. Realization of the system

The concept of designing this device can provide increased safety in the cooking process and reduce the chance of a house fire caused by forgetting to turn off the gas stove. In designing an automatic gas stove with Wi-Fi transmission, several modules were used, namely solenoid valve, Wi-Fi module, microcontroller module, power supply module, passive infrared (PIR) sensor module, gas sensor module, digital timer module. These modules had their respective functions. For example, the PIR sensor module [7] triggered the microcontroller, then at that time the microcontroller [8-9] triggered a digital timer that had been adjusted for the time if the PIR sensor did not detect any movement in the area near the gas stove. After the set time was up, it would send information to Android application on a smartphone.

When the set time ran out, the microcontroller also sent information using Wi-Fi in the system to connect to the internet. Information was sent and could be accessed via the application on the Android smartphone for gas stove users. Gas stove users could the turn off the gas stove when it was still on. This secured system was also equipped with a gas sensor. If there was a gas leak [10], it would provide input to the microcontroller. The microcontroller also sent information in the form of danger notifications to gas stove users via an application on a smartphone using an Internet connection. The block diagram of the designed and implemented secured automatic gas stove system with Wi-Fi transmission and Android application on smartphone can be seen in Figure 1.

The design realization of the overall system was done by unifying all modules into one unified system. The gas detection circuit module, the PIR motion sensor module, the timer module and the solenoid valve [11] were connected to the NodeMCU. NodeMCU [12] acted as a processor to regulate each input

and output. The system could run when it got the voltage and current generated by the power supply module. The 5-Volt voltage from the power supply was used to power the NodeMCU and all modules in this secured gas stove system. All modules in the system were placed in a container, the gas sensor module was located close to the gas cylinder, and the power supply module was outside the gas stove. The schematic diagram of the whole system circuit can be seen in Figure 2.

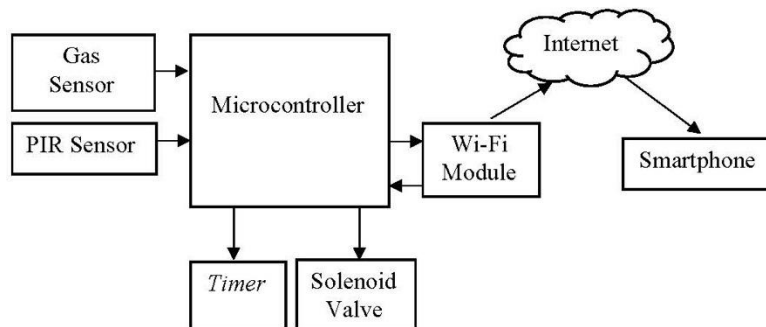

Figure 1. Block diagram of the designed automatic secured gas stove system

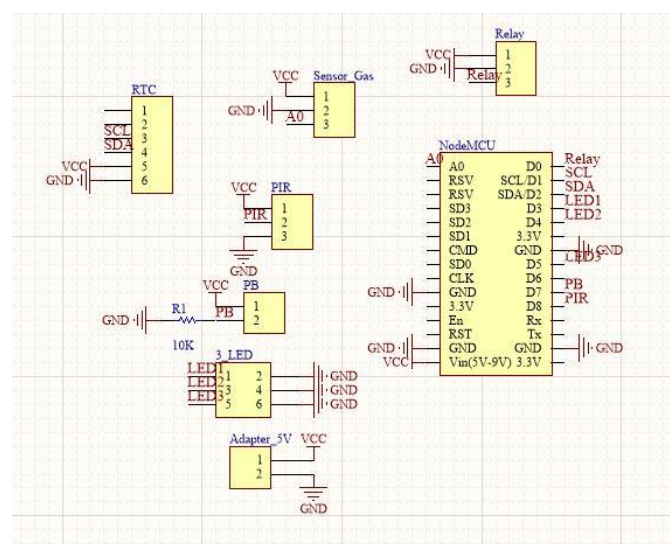

Figure 2. Schematic diagram of the whole system circuit

Push button provided input to NodeMCU when the push button was pressed. NodeMCU outputted the first timer so that the first timer would count the time that had been set. If the timer ran out, it would give input to NodeMCU. NodeMCU [13-14] would process the data and provided output for the relay so that the changing condition of the relay caused the gas solenoid valve to work. Then the gas stove would automatically shut down. Apart from the push button, the input also came from the PIR motion sensor module. The PIR detected movement near the gas stove. When the PIR did not detect movement, NodeMCU would process the data and provided an output for the second timer so that the timer calculated the predetermined time. When the time was up, NodeMCU would change its function to a Wi-Fi module that will send information to application on Android via an internet connection. Android application [15-16] would display information that the stove was still on. The view of the realized whole system can be seen in Figure 3.

4. Results and discussion

Testing the whole system was done by connecting all existing modules. The system power supply was used as a voltage source to power the entire module that was designed in the system. The gas sensor module, the PIR sensor module, the timer module and the gas solenoid valve were all connected to the NodeMCU.



Figure 3. Realized overall system

The test step was carried out by checking the gas on the regulator installation in the LP gas cylinder using the gas sensor module. If the gas sensor module could detect a gas leak between the regulator and the LP gas cylinder, the LED will light up. After the gas stove was turned on, timer 1 started counting according to the predetermined time and when the time set on timer 1 ran out, it sent data to NodeMCU and the gas solenoid valve closed automatically. After that the PIR sensor would detect the presence or absence of movement near the gas stove, if there was no movement near the gas stove, the PIR sensor triggered timer 2 and when the set time on timer 2 ran out, it sent data to NodeMCU and NodeMCU sent information with an internet connection to the smartphone of the gas stove user. On the Android smartphone application, information of the condition of the gas stove was displayed. Testing results of the whole system can be seen in Table 1.

Tabel 1. Testing results of the whole system

No.	Type of testing	Result
1.	Power supply module can supply the whole circuit	succeed
2.	Gas sensor can detect gas leaks	succeed
3.	PIR sensor module can detect movement	succeed
4.	Solenoid valve can stop gas flow	succeed
5.	NodeMCU module can connect system to network	succeed
6.	NodeMCU module can send data via internet	succeed
7.	Information can be displayed on smartphone application	succeed

5. Conclusion

Based on the results of testing and analysis of the system designed, the following conclusions can be drawn. At first, the gas sensor could detect a gas leak if it had passed the value of 300 ppm. Second, Android application was designed to display information in accordance with the condition of the system that was running and could turn off the stove by pressing a button on it. The information displayed on the built Android application was the condition of the gas stove whether it was on or off. At last, solenoid valve was successful in stopping the flow of gas from the gas cylinder to the gas stove. All functions of the overall system could work well as expected in the design stage.

6. References

- [1] Fire and Rescue Service 2019 Fire statistics by causes <http://www.jakartafire.net>
- [2] Abdullah and Masthura 2018 Automatic plant nutrition and watering system based on real time clock and soil moisture level based on ATMEGA32 microcontroller *J. Ilmu Fisika dan Teknologi* **2(2)** 33-41
- [3] M A Kurniawan and Tjahjadi G 2016 Automatic safety of one furnace LP gas stove based on ATmega 16 microcontroller *JETri* **14(1)** 19-34
- [4] Rusimamto P W and Rohma F J 2017 Design of conventional lpg gas stove automatic control system design for boiling water based on arduino uno *J. Teknik Elektro* **6(3)** 163-173
- [5] Harmoko, Sanjaya B W and Wigyarianto F T P 2017 Smart gas stove design based on arduino mega microcontroller *J. Teknik Elektro Untan* **1(1)** 1-7
- [6] PT. Covina Industri Italindo 2019 Gas stove covina cp-351 xx <http://www.covina.co.id/product/kompor-gas-covina-cp-351-xx>
- [7] Ahadiyah S, Muharnis and Agustawan 2017 PIR sensor implementation in microcontroller-based electronic equipment *J. INOVTEK POLBENG* **7(1)** 29-34
- [8] Sumarsono and Saptaningtyas D W 2018 Microcontroller development as a remote control based on android *J. Teknik Informatika UIN Jakarta* **11(1)** 67-74
- [9] Chamim A N N 2010 Use of a microcontroller as a position detector using a gsm signal *J. Informatika* **4(1)** 430-439
- [10] Mahmud H, Wahjudi A and Sudarmanta B 2014 Design a controller circuit for valves used as gas inlets on oxygen sensor calibration tools *J. Teknik POMITS* **1(2)** 1-6
- [11] Suhaedi 2012 HS133 gas sensor design as a leak detector in lpg gas *J. Ilmiah Politeknik Balikpapan* **4(1)** 1-5
- [12] Titahningsih P, Primananda R and Akbar S R 2015 Access point placement planning for wi-fi networks on passenger trains *J. Pengembangan Teknologi Informasi dan Ilmu Komputer* **2(5)** 2008-2015
- [13] Rahmatika V 2017 Design of a gas stove setting system using an android-based arduino *Bachelor Thesis Politeknik Negeri Sriwijaya*
- [14] Hugeng H, Gunawan D and Kusumo A T 2019 Enhanced speech recognition for indonesian geographic dictionary using deep learning *Int. J. of Innovative Technology and Exploring Engineering* **8(11)** 2594-2598
- [15] Lengkong H N, Sinsuw A A E and Lumenta A S M 2015 Designing routes for private vehicles using an android-based gis mobile application integrated on google maps *J. T. Elektro dan Komputer* **4(2)** 18-25
- [16] Anwar A N A, Maulana R and Kurniawan W 2018 Design of flame stabilization system for portable stoves using ultrasonic sensors and temperature sensors with fuzzy method *J. Pengembangan Teknologi Informasi dan Ilmu Komputer* **2(10)** 3827-3836