



# INTERNATIONAL JOURNAL OF APPLICATION ON ECONOMICS AND BUSINESS

**IJAEB**



# INTERNATIONAL JOURNAL OF APPLICATION ON ECONOMICS AND BUSINESS

**IJAEB**

Graduate Program of Universitas Tarumanagara

Address:

Graduate Program of Universitas Tarumanagara

Universitas Tarumanagara

Kampus 1, Jl. Letjen S. Parman No. 1

Jakarta 11440, Indonesia



VOL. 1 NO. 3

AUGUST 2023



Home (<https://journal.untar.ac.id/index.php/ijaeb/index>) / Editorial Team

## Editorial Team

### Editor in Chief

*Hetty Karunia Tunjungsari*  (mailto:  
%68%65%74%74%79@%66%65.%75%6e%74%61%72.%61%63.%69%64)  
Universitas Tarumanagara, Indonesia



(<https://scholar.google.co.id/citations?>

user=4KKYicUAAAAJ&hl=id&oi=ao)



(<http://sinta2.ristekdikti.go.id/>

authors/detail?id=5995723&view=overview)



ResearchGate

([https://www.researchgate.net/profile/Hetty\\_Tunjungsari](https://www.researchgate.net/profile/Hetty_Tunjungsari))

### Executive Editor

*Linda Linchin Lin*  (mailto:%68%65%74%74%79@%66%65.%75%6e%74%61%72.%61%63.%69%64)  
Kunshan University, Taiwan

*Lai Yin Ling*  (<https://newinti.edu.my/campuses/inti-international-university/>)  
INTI International University, Malaysia

### Managing Editor

*Cokki Cokki*  (<http://dosen.untar.ac.id/dosen/detail-JmJmYmJJ-ind.html>)

Universitas Tarumanagara, Indonesia

*Teoh Ai Ping*  (<https://gsb.usm.my/personnel/assoc-prof-ts-dr-teoh-ai-ping/>)  
Universiti Sains Malaysia, Malaysia

*Masmira Kurniawati*  (<https://feb.unair.ac.id/tentang-feb-unair/profil-dosen/staf-pengajar-manajemen/6419-dr-masmira-kurniawati-se-m-si.html>)  
Airlangga University, Indonesia

### Section Editor

*Galuh Mira Saktiana*  (<http://dosen.untar.ac.id/dosen/detail-JmJJmmJ-ind.html>)

Universitas Tarumanagara, Indonesia

*Halim Putera Siswanto*  (<http://dosen.untar.ac.id/dosen/detail-JmJmymmmJ-ind.html>)

Universitas Tarumanagara, Indonesia

#### TOOLS

use APA style, download here



([https://cs1.mendeley.com/styleInfo/?](https://cs1.mendeley.com/styleInfo/?styleId=http%3A%2F%2Fwww.zotero.org%2Fstyles%2Fapa)

[styleId=http%3A%2F%2Fwww.zotero.org%2Fstyles%2Fapa](https://cs1.mendeley.com/styleInfo/?styleId=http%3A%2F%2Fwww.zotero.org%2Fstyles%2Fapa))

#### Template



([https://docs.google.com/document/d/1h39XGU5\\_5eMJAXhKGSvEGVhpxMrxwRCF/](https://docs.google.com/document/d/1h39XGU5_5eMJAXhKGSvEGVhpxMrxwRCF/edit?usp=share_link&oid=112826885138839568747&rtpof=true&sd=true)

[edit?usp=share\\_link&oid=112826885138839568747&rtpof=true&sd=true](https://docs.google.com/document/d/1h39XGU5_5eMJAXhKGSvEGVhpxMrxwRCF/edit?usp=share_link&oid=112826885138839568747&rtpof=true&sd=true))

#### PROFILE MENU

---

Contact

---

Editorial Team (</index.php/ijaeb/about/editorialTeam>)

---

Focus and Scope (</index.php/ijaeb/about#focusAndScope>)

---

Indexing

---

Web Analytics (<https://statcounter.com/p12907097/summary/>)

View My Stats (<https://statcounter.com/p12844469/?guest=1>)

#### ISSN

ISSN 2987-1972



(<https://issn.brin.go.id/terbit/detail/20230426411707807>)

ISSN PUSAT NASIONAL ISSN INDONESIA (<https://issn.brin.go.id/terbit/detail/20230426411707807>)

Indexed by :



(<https://scholar.google.com/citations?hl=id&user=UuFn->

joAAAAJ&view\_op=list\_works&authuser=2&gmla=AOV7GLMmf1WMkuBiJJMC0LiHjEROH-c\_rOjP\_5mNgA2HCGL6-7p0men-j8wm22Zu3MGLdhGHqGsTFvVj60JgtCV4)



(<https://www.mendeley.com/profiles/jurnal-muara-ilmu-ekonomi->

dan/publications/)



(<https://app.dimensions.ai/discover/publication?>

search\_mode=content&search\_text=10.24912%2Fijaeb&search\_type=kws&search\_field=text\_search)



(<https://portal.issn.org/resource/ISSN/2987-1972>)



(<https://garuda.kemdikbud.go.id/journal/view/31672>)



(<https://journals.indexcopernicus.com/search/details?>

id=128371&lang=en)



(<http://untar.ac.id/>)

**UNTAR**  
Universitas Tarumanagara

Graduate Program of Universitas Tarumanagara

# Platform &

# workflow by OJS / PKP

(<https://journal.untar.ac.id/index.php/ijaeb/about/aboutThisPublishingSystem>)

Home (<https://journal.untar.ac.id/index.php/ijaeb/index>)  
 / Archives (<https://journal.untar.ac.id/index.php/ijaeb/issue/archive>)  
 / Vol. 1 No. 3 (2023): Agustus 2023





**Published:** 2023-08-28

## Articles

THE IMPACT OF LIQUIDITY, PROFITABILITY, AND LEVERAGE ON FIRM VALUE WITH DIVIDEND POLICY AS MODERATING VARIABLE (<https://journal.untar.ac.id/index.php/ijaeb/article/view/26846>)

Stefanie Stefanie, Yanti Yanti  
 899-910

PDF (<https://journal.untar.ac.id/index.php/ijaeb/article/view/26846/16138>)



 Abstract views: 1 |  Download : 0

 <https://doi.org/10.24912/ijaeb.v1i3.899-910> (<https://doi.org/10.24912/ijaeb.v1i3.899-910>)

## FINANCIAL LITERACY TECHNOLOGY ADOPTION IN INDONESIAN SHARIA BANKING: A PRELIMINARY ANALYSIS (<https://journal.untar.ac.id/index.php/ijaeb/article/view/26847>)

Riana Magdalena Silitonga, Yung-Tsan Jou, Ronald Sukwadi, Ferdian Aditya Pratama  
911-920

PDF (<https://journal.untar.ac.id/index.php/ijaeb/article/view/26847/16139>)



|  Abstract views: 0 |  Download :0

 <https://doi.org/10.24912/ijaeb.v1i3.911-920> (<https://doi.org/10.24912/ijaeb.v1i3.911-920>)

## THE IMPACT OF COVID-19, TRADING VOLUME ACTIVITY AND MARKET CAPITALIZATION ON STOCK RETURN OF LQ-45 COMPANIES (<https://journal.untar.ac.id/index.php/ijaeb/article/view/26848>)

Nadya Aurelia Chandra, Rousilita Suhendah  
921-933

PDF (<https://journal.untar.ac.id/index.php/ijaeb/article/view/26848/16140>)



|  Abstract views: 0 |  Download :0

 <https://doi.org/10.24912/ijaeb.v1i3.921-933> (<https://doi.org/10.24912/ijaeb.v1i3.921-933>)

## ANALYSIS OF VARIABLES INFLUENCING CONSUMER PURCHASE INTENTION ON TOKOPEDIA (<https://journal.untar.ac.id/index.php/ijaeb/article/view/26849>)

Charisma Dwilestari, Rezi Erdiansyah  
934-945

PDF (<https://journal.untar.ac.id/index.php/ijaeb/article/view/26849/16141>)



|  Abstract views: 0 |  Download :0

 <https://doi.org/10.24912/ijaeb.v1i3.934-945> (<https://doi.org/10.24912/ijaeb.v1i3.934-945>)

## DETERMINANTS OF DEBT POLICY IN CONSUMER GOODS COMPANY IN INDONESIA (<https://journal.untar.ac.id/index.php/ijaeb/article/view/26850>)

Nurainun Bangun, Khairina Natsir, Ngadiman Ngadiman  
946-956

PDF (<https://journal.untar.ac.id/index.php/ijaeb/article/view/26850/16142>)



|  Abstract views: 0 |  Download :0

 <https://doi.org/10.24912/ijaeb.v1i3.946-956> (<https://doi.org/10.24912/ijaeb.v1i3.946-956>)

## MARKETING STRATEGY INNOVATION IN THE FRAMEWORK TOWARDS EXPANSION OF DIGITAL BANK ACCESS AROUND STUDENTS (A CASE STUDY ON BLU BCA) (<https://journal.untar.ac.id/index.php/ijaeb/article/view/26851>)

Septihani Michella Wijaya, Angely Olivia Putri, Andi Wijaya  
957-967

PDF (<https://journal.untar.ac.id/index.php/ijaeb/article/view/26851/16143>)



|  Abstract views: 0 |  Download :0

 <https://doi.org/10.24912/ijaeb.v1i3.957-967> (<https://doi.org/10.24912/ijaeb.v1i3.957-967>)

## FACTORS THAT INCREASE PURCHASE INTENTION OF ELECTRIC CARS IN JAKARTA (<https://journal.untar.ac.id/index.php/ijaeb/article/view/26852>)

Tommy Setiawan Ruslim, Kevin Setiawan, Claudia Gita Hapsari, Dyah Erny Herwindiati  
968-977

PDF (<https://journal.untar.ac.id/index.php/ijaeb/article/view/26852/16144>)



|  Abstract views: 0 |  Download :0

 <https://doi.org/10.24912/ijaeb.v1i3.968-977> (<https://doi.org/10.24912/ijaeb.v1i3.968-977>)

## ENTREPRENEURIAL ORIENTATION AMONG MSMES IN BALI'S ECONOMIC RECOVERY DURING COVID-19 PANDEMIC (<https://journal.untar.ac.id/index.php/ijaeb/article/view/26853>)

Tiara Carina, Ni Made Indah Mentari, I Dewa Made Arik Permana Putra, Putu Melani Gita Sari, Putu Tasiya Purnama Dewi  
978-991

PDF (<https://journal.untar.ac.id/index.php/ijaeb/article/view/26853/16145>)



|  Abstract views: 0 |  Download :0

 <https://doi.org/10.24912/ijaeb.v1i3.978-991> (<https://doi.org/10.24912/ijaeb.v1i3.978-991>)

## PROTECTION OF CAPITAL MARKET RETAIL INVESTOR INTERESTS AGAINST DUAL CLASS VOTING SYSTEMS (<https://journal.untar.ac.id/index.php/ijaeb/article/view/26854>)

Suwinto Johan, Gunardi Lie  
992-999

PDF (<https://journal.untar.ac.id/index.php/ijaeb/article/view/26854/16146>)



|  Abstract views: 1 |  Download :0

 <https://doi.org/10.24912/ijaeb.v1i3.992-999> (<https://doi.org/10.24912/ijaeb.v1i3.992-999>)

## FACTORS AFFECTING EPS ON NON-CYCLICALS CONSUMER SECTOR COMPANIES LISTED ON THE IDX (<https://journal.untar.ac.id/index.php/ijaeb/article/view/26855>)

Veronica Herman, Sufiyati Sufiyati  
1000-1010

PDF (<https://journal.untar.ac.id/index.php/ijaeb/article/view/26855/16147>)



|  Abstract views: 0 |  Download :0

 <https://doi.org/10.24912/ijaeb.v1i3.1000-1010> (<https://doi.org/10.24912/ijaeb.v1i3.1000-1010>)

## FACTORS AFFECTING EARNINGS MANAGEMENT IN MANUFACTURING COMPANIES LISTED ON INDONESIAN STOCK EXCHANGE (<https://journal.untar.ac.id/index.php/ijaeb/article/view/26856>)

Syelly Gunawan, Sufiyati Sufiyati  
1011-1024

PDF (<https://journal.untar.ac.id/index.php/ijaeb/article/view/26856/16148>)

|  Abstract views: 0 |  Download :0





 <https://doi.org/10.24912/ijaeb.v1i3.1011-1024> (<https://doi.org/10.24912/ijaeb.v1i3.1011-1024>)

### FACTORS AFFECTING ACCOUNTING CONSERVATISM IN CONSUMER GOODS COMPANIES IN INDONESIA STOCK EXCHANGE (<https://journal.untar.ac.id/index.php/ijaeb/article/view/26857>)

Arlia Natasya Hadi, Susanto Salim  
1025-1037

PDF (<https://journal.untar.ac.id/index.php/ijaeb/article/view/26857/16149>)



|  Abstract views: 0 |  Download :0

 <https://doi.org/10.24912/ijaeb.v1i3.1025-1037> (<https://doi.org/10.24912/ijaeb.v1i3.1025-1037>)

### FACTORS INFLUENCING SUSTAINABILITY REPORT DISCLOSURE ON MINING COMPANIES LISTED IN IDX (<https://journal.untar.ac.id/index.php/ijaeb/article/view/26858>)

Mourend Gabriella Karundeng, Susanto Salim  
1038-1049

PDF (<https://journal.untar.ac.id/index.php/ijaeb/article/view/26858/16150>)



|  Abstract views: 0 |  Download :0

 <https://doi.org/10.24912/ijaeb.v1i3.1038-1049> (<https://doi.org/10.24912/ijaeb.v1i3.1038-1049>)

### THE EFFECT OF PROFITABILITY, CAPITAL STRUCTURE, FIRM SIZE, AND ASSET GROWTH ON FIRM VALUE (<https://journal.untar.ac.id/index.php/ijaeb/article/view/26863>)

Angelina William Boenyamin, Linda Santioso  
1097-1107

PDF (<https://journal.untar.ac.id/index.php/ijaeb/article/view/26863/16155>)



|  Abstract views: 0 |  Download :0

 <https://doi.org/10.24912/ijaeb.v1i3.1097-1107> (<https://doi.org/10.24912/ijaeb.v1i3.1097-1107>)

### THE INFLUENCE OF EXCHANGEABILITY, LEVERAGE, INFLATION, AND INTEREST RATE ON FINANCIAL PROBLEMS AMONG MANUFACTURING COMPANIES LISTED ON INDONESIA STOCK EXCHANGE DURING 2018-2021 (<https://journal.untar.ac.id/index.php/ijaeb/article/view/26860>)

I Gede Adiputra, Herman Ruslim  
1062-1073

PDF (<https://journal.untar.ac.id/index.php/ijaeb/article/view/26860/16152>)



|  Abstract views: 0 |  Download :0

 <https://doi.org/10.24912/ijaeb.v1i3.1062-1073> (<https://doi.org/10.24912/ijaeb.v1i3.1062-1073>)

### FACTOR AFFECTING DIVIDEND POLICY IN FINANCIAL SECTOR COMPANIES IN INDONESIA STOCK EXCHANGE (<https://journal.untar.ac.id/index.php/ijaeb/article/view/26864>)

Katherine Magdalena, Linda Santioso  
1108-1119

PDF (<https://journal.untar.ac.id/index.php/ijaeb/article/view/26864/16156>)



|  Abstract views: 0 |  Download :0

 <https://doi.org/10.24912/ijaeb.v1i3.1108-1119> (<https://doi.org/10.24912/ijaeb.v1i3.1108-1119>)

### THE EFFECT OF FINANCIAL RATIOS ON FINANCIAL PERFORMANCE AMONG BANKING COMPANIES (<https://journal.untar.ac.id/index.php/ijaeb/article/view/26861>)

Annetta Cathleen, Agustin Ekadjaja  
1074-1086

PDF (<https://journal.untar.ac.id/index.php/ijaeb/article/view/26861/16153>)



|  Abstract views: 0 |  Download :0

 <https://doi.org/10.24912/ijaeb.v1i3.1074-1086> (<https://doi.org/10.24912/ijaeb.v1i3.1074-1086>)

### PROFITABILITY, COMPANY SIZE, DIVIDENDS, AND CAPITAL STRUCTURE EFFECTS ON COMPANY'S VALUE (<https://journal.untar.ac.id/index.php/ijaeb/article/view/26862>)

Karin Oxana Wongso, Agustin Ekadjaja  
1087-1096

PDF (<https://journal.untar.ac.id/index.php/ijaeb/article/view/26862/16154>)



|  Abstract views: 0 |  Download :0

 <https://doi.org/10.24912/ijaeb.v1i3.1087-1096> (<https://doi.org/10.24912/ijaeb.v1i3.1087-1096>)

### THE EFFECT OF PROFITABILITY AND LIQUIDITY ON CAPITAL STRUCTURE WITH FIRM SIZE AS MODERATING VARIABLE (<https://journal.untar.ac.id/index.php/ijaeb/article/view/26889>)

Angelina Richie Kho, Merry Susanti  
1351-1359

PDF (<https://journal.untar.ac.id/index.php/ijaeb/article/view/26889/16179>)



|  Abstract views: 0 |  Download :0

 <https://doi.org/10.24912/ijaeb.v1i3.1351-1359> (<https://doi.org/10.24912/ijaeb.v1i3.1351-1359>)

### THE IMPACT OF ASSET MANAGEMENT, CAPITAL STRUCTURE, AND FIRM SIZE TOWARD PROFITABILITY (<https://journal.untar.ac.id/index.php/ijaeb/article/view/26865>)

Priskila Priskila , Sofia Prima Dewi  
1120-1132

PDF (<https://journal.untar.ac.id/index.php/ijaeb/article/view/26865/16157>)



|  Abstract views: 0 |  Download :0

 <https://doi.org/10.24912/ijaeb.v1i3.1120-1132> (<https://doi.org/10.24912/ijaeb.v1i3.1120-1132>)

## THE DETERMINANTS OF FIRM VALUE (<https://journal.untar.ac.id/index.php/ijaeb/article/view/26866>)

Luh Ketut Kumari Chandra Warsiki, Sofia Prima Dewi  
1133-1145

PDF (<https://journal.untar.ac.id/index.php/ijaeb/article/view/26866/16158>)



|  Abstract views: 0 |  Download :0

 <https://doi.org/10.24912/ijaeb.v1i3.1133-1145> (<https://doi.org/10.24912/ijaeb.v1i3.1133-1145>)

## FACTORS AFFECTING DIVIDEND POLICY WITH BUSINESS RISK AS MODERATION VARIABLES (<https://journal.untar.ac.id/index.php/ijaeb/article/view/26867>)

Rini Tri Hastuti, Ardhiyansyah Rasyid, Ari Pambudi  
1146-1156

PDF (<https://journal.untar.ac.id/index.php/ijaeb/article/view/26867/16159>)



|  Abstract views: 0 |  Download :0

 <https://doi.org/10.24912/ijaeb.v1i3.1146-1156> (<https://doi.org/10.24912/ijaeb.v1i3.1146-1156>)

## FACTORS AFFECTING DIVIDEND PAY OUT RATIO WITH ROE (RETURN ON EQUITY) AS MODERATING VARIABLE (<https://journal.untar.ac.id/index.php/ijaeb/article/view/26868>)

Rini Tri Hastuti, Richard Andrew  
1157-1164

PDF (<https://journal.untar.ac.id/index.php/ijaeb/article/view/26868/16160>)



|  Abstract views: 0 |  Download :0

 <https://doi.org/10.24912/ijaeb.v1i3.1157-1164> (<https://doi.org/10.24912/ijaeb.v1i3.1157-1164>)

## INFLATION VALUE FORECASTING POST COVID-19 IN DENPASAR USING ARIMA (<https://journal.untar.ac.id/index.php/ijaeb/article/view/26869>)

Ni Putu Ayu Mirah Mariati, Luh Pande Eka Setiawati, Ni Luh Putu Sandrya Dewi  
1165-1169

PDF (<https://journal.untar.ac.id/index.php/ijaeb/article/view/26869/16161>)



|  Abstract views: 0 |  Download :0

 <https://doi.org/10.24912/ijaeb.v1i3.1165-1169> (<https://doi.org/10.24912/ijaeb.v1i3.1165-1169>)

## FACTORS AFFECTING ACCOUNTING INFORMATION SYSTEM PERFORMANCE IN CV. HARI BAIK (<https://journal.untar.ac.id/index.php/ijaeb/article/view/26870>)

Ni Luh Nyoman Sherina Devi, Ida Ayu Ratih Manuari, RR. Maria Yulia Dwi Rengganis, Luh Putri Mas Mirayani, Yura Karlinda Wiasa Putri  
1170-1181

PDF (<https://journal.untar.ac.id/index.php/ijaeb/article/view/26870/16162>)



|  Abstract views: 0 |  Download :0

 <https://doi.org/10.24912/ijaeb.v1i3.1170-1181> (<https://doi.org/10.24912/ijaeb.v1i3.1170-1181>)

### FIRM VALUE OF THE PROPERTY, REAL ESTATE & BUILDING SECTOR IN INDONESIA AT THE BEGINNING OF THE COVID-19 PANDEMIC (<https://journal.untar.ac.id/index.php/ijaeb/article/view/26871>)

Indah Kusuma, Rayhita Santhi, Cahyadi Putra  
1182-1189

PDF (<https://journal.untar.ac.id/index.php/ijaeb/article/view/26871/16163>)



|  Abstract views: 0 |  Download :0

 <https://doi.org/10.24912/ijaeb.v1i3.1182-1189> (<https://doi.org/10.24912/ijaeb.v1i3.1182-1189>)

### THE INFLUENCE OF SUBJECTIVE NORMS, TAX SOCIALIZATION AND TAX ADMINISTRATION SERVICES TO MSMES INDIVIDUAL TAX COMPLIANCE WHO REGISTERED AT NORTH JAKARTA REGIONAL TAX OFFICE (<https://journal.untar.ac.id/index.php/ijaeb/article/view/26872>)

Carsen Finrely, Yuniarwati Yuniarwati  
1190-1209

PDF (<https://journal.untar.ac.id/index.php/ijaeb/article/view/26872/16164>)



|  Abstract views: 0 |  Download :0

 <https://doi.org/10.24912/ijaeb.v1i3.1190-1209> (<https://doi.org/10.24912/ijaeb.v1i3.1190-1209>)

### THE APPLICATION OF RESPONSIBILITY EDUCATION ON SUSTAINABILITY ISSUES (<https://journal.untar.ac.id/index.php/ijaeb/article/view/26873>)

Shieunt-Han Tsai, I-H Yang  
1210-1217

PDF (<https://journal.untar.ac.id/index.php/ijaeb/article/view/26873/16165>)



|  Abstract views: 0 |  Download :0

 <https://doi.org/10.24912/ijaeb.v1i3.1210-1217> (<https://doi.org/10.24912/ijaeb.v1i3.1210-1217>)

### ANALYSIS OF THE EFFECT OF INTEGRATING DIGITAL GAME-BASED DECISION-MAKING INTO THE APPROPRIATE TEACHING OF BUSINESS ETHICS (<https://journal.untar.ac.id/index.php/ijaeb/article/view/26874>)

Che-Fei Chen  
1218-1226

PDF (<https://journal.untar.ac.id/index.php/ijaeb/article/view/26874/16166>)



|  Abstract views: 0 |  Download :0

 <https://doi.org/10.24912/ijaeb.v1i3.1218-1226> (<https://doi.org/10.24912/ijaeb.v1i3.1218-1226>)

### CASE STUDY OF INNOVATION BUSINESS MODEL TO PROMOTE SUSTAINABLE AGRICULTURE OF PRIVATE FARM IN TAIWAN (<https://journal.untar.ac.id/index.php/ijaeb/article/view/26875>)

Shun-Cheng Chang, Chin-Chiuan Lin  
1227-1236

PDF (<https://journal.untar.ac.id/index.php/ijaeb/article/view/26875/16167>)



 Abstract views: 0 |  Download :0

 <https://doi.org/10.24912/ijaeb.v1i3.1227-1236> (<https://doi.org/10.24912/ijaeb.v1i3.1227-1236>)

IS WORKPLACE FRIENDSHIP IMPORTANT ON THE RELATIONSHIP BETWEEN EMOTIONAL EXHAUSTION AND ORGANIZATIONAL CITIZENSHIP BEHAVIOR- TAKE PRESCHOOL TEACHER IN TAINAN AS SAMPLES (<https://journal.untar.ac.id/index.php/ijaeb/article/view/26876>)

Yi-Chen Chen, Pei-Yu Sung  
1237-1244

PDF (<https://journal.untar.ac.id/index.php/ijaeb/article/view/26876/16168>)



 Abstract views: 0 |  Download :0

 <https://doi.org/10.24912/ijaeb.v1i3.1237-1244> (<https://doi.org/10.24912/ijaeb.v1i3.1237-1244>)

THE MEDIATING EFFECT OF PLACE ATTACHMENT ON THE RELATIONSHIP BETWEEN SENIOR CITIZEN ACTIVITY INVOLVEMENT AND ACTIVITY SATISFACTION - A CASE FROM THE PERSPECTIVE OF LEISURE MANAGEMENT (<https://journal.untar.ac.id/index.php/ijaeb/article/view/26877>)

Yi-Chen Chen, Ching-Wen Chiang  
1245-1255

PDF (<https://journal.untar.ac.id/index.php/ijaeb/article/view/26877/16169>)



 Abstract views: 0 |  Download :0

 <https://doi.org/10.24912/ijaeb.v1i3.1245-1255> (<https://doi.org/10.24912/ijaeb.v1i3.1245-1255>)

CASE STUDY OF THE ESTABLISHMENT OF MAINTENANCE MECHANISM OF INJECTION MACHINE (<https://journal.untar.ac.id/index.php/ijaeb/article/view/26878>)

Chin-Chiuan Lin, Yen-Wen Shih  
1256-1264

PDF (<https://journal.untar.ac.id/index.php/ijaeb/article/view/26878/16170>)



 Abstract views: 0 |  Download :0

 <https://doi.org/10.24912/ijaeb.v1i3.1256-1264> (<https://doi.org/10.24912/ijaeb.v1i3.1256-1264>)

EXPLORING THE ENTREPRENEURIAL INTENTION OF GENERATION Y PEOPLE IN THAILAND (<https://journal.untar.ac.id/index.php/ijaeb/article/view/26879>)

Cheng-Lung Li, Yurika Ngamvutteyaporn  
1265-1274

PDF (<https://journal.untar.ac.id/index.php/ijaeb/article/view/26879/16171>)

 Abstract views: 0 |  Download :0



 <https://doi.org/10.24912/ijaeb.v1i3.1265-1274> (<https://doi.org/10.24912/ijaeb.v1i3.1265-1274>)

CASE STUDY OF CONSTRUCTED A PROSPEROUS FOOD RESTAURANT BASE ON

## INNOVATIVE BUSINESS MODEL (<https://journal.untar.ac.id/index.php/ijaeb/article/view/26881>)

Te-Tsai Lu, Shu-Fen Shen  
1275-1284

PDF (<https://journal.untar.ac.id/index.php/ijaeb/article/view/26881/16172>)



|  Abstract views: 0 |  Download :0

 <https://doi.org/10.24912/ijaeb.v1i3.1275-1284> (<https://doi.org/10.24912/ijaeb.v1i3.1275-1284>)

## THE COMPARISON OF BUSINESS MODELS AMONG ELDERLY DAY CARE CENTRES IN TAIWAN (<https://journal.untar.ac.id/index.php/ijaeb/article/view/26882>)

Tai-Ho Yang, Hsia Pan, Te-Tsai Lu  
1285-1294

PDF (<https://journal.untar.ac.id/index.php/ijaeb/article/view/26882/16173>)



|  Abstract views: 0 |  Download :0

 <https://doi.org/10.24912/ijaeb.v1i3.1285-1294> (<https://doi.org/10.24912/ijaeb.v1i3.1285-1294>)

## FACTORS AFFECTING OUTSOURCING DECISIONS FOR FACILITY MANAGEMENT SERVICES (<https://journal.untar.ac.id/index.php/ijaeb/article/view/26883>)

Nichakorn Veerakul  
1295-1306

PDF (<https://journal.untar.ac.id/index.php/ijaeb/article/view/26883/16174>)



|  Abstract views: 0 |  Download :0

 <https://doi.org/10.24912/ijaeb.v1i3.1295-1306> (<https://doi.org/10.24912/ijaeb.v1i3.1295-1306>)

## THE EFFECT OF THE FRAUD TRIANGLE IN DETECTING FRAUDULENT FINANCIAL REPORTING IN INDONESIAN BANKING SECTOR COMPANIES (<https://journal.untar.ac.id/index.php/ijaeb/article/view/26884>)

Rico Ricardo, Rousilita Suhendah  
1307-1317

PDF (<https://journal.untar.ac.id/index.php/ijaeb/article/view/26884/16175>)



|  Abstract views: 0 |  Download :0

 <https://doi.org/10.24912/ijaeb.v1i3.1307-1317> (<https://doi.org/10.24912/ijaeb.v1i3.1307-1317>)

## THE EFFECT OF CAPITAL STRUCTURE, LIQUIDITY, PROFITABILITY, ACTIVITY, AND INSTITUTIONAL OWNERSHIP ON COMPANY VALUE AMONG MANUFACTURING COMPANIES LISTED ON INDONESIA STOCK EXCHANGE DURING 2017-2022 (<https://journal.untar.ac.id/index.php/ijaeb/article/view/26885>)

Christina Tania, Merry Susanti  
1318-1327

PDF (<https://journal.untar.ac.id/index.php/ijaeb/article/view/26885/16176>)



|  Abstract views: 0 |  Download :0

 <https://doi.org/10.24912/ijaeb.v1i3.1318-1327> (<https://doi.org/10.24912/ijaeb.v1i3.1318-1327>)

### ANALYSIS OF FACTORS INFLUENCING MCDONALD'S CONSUMER PURCHASE DECISION IN JAKARTA (<https://journal.untar.ac.id/index.php/ijaeb/article/view/26886>)

Clarissa Fortuna, Carunia Mulya Firdausy  
1328-1338

PDF (<https://journal.untar.ac.id/index.php/ijaeb/article/view/26886/16177>)



|  Abstract views: 0 |  Download :0

 <https://doi.org/10.24912/ijaeb.v1i3.1328-1338> (<https://doi.org/10.24912/ijaeb.v1i3.1328-1338>)

### TESTING THE EFFECT OF SUBJECTIVE NORM MODERATION ON LUXURY PRODUCTS (<https://journal.untar.ac.id/index.php/ijaeb/article/view/26888>)

Febby Ariamurti, Hetty Karunia Tunjungsari  
1339-1350

PDF (<https://journal.untar.ac.id/index.php/ijaeb/article/view/26888/16178>)



|  Abstract views: 0 |  Download :0

 <https://doi.org/10.24912/ijaeb.v1i3.1339-1350> (<https://doi.org/10.24912/ijaeb.v1i3.1339-1350>)

### THE EFFECT OF PROFITABILITY, CAPITAL STRUCTURE, ASSET STRUCTURE, AND FIRM AGE ON FIRM VALUE (<https://journal.untar.ac.id/index.php/ijaeb/article/view/26859>)

Serena Beatrice Harsono, Liana Susanto  
1050-1061

PDF (<https://journal.untar.ac.id/index.php/ijaeb/article/view/26859/16151>)



|  Abstract views: 0 |  Download :0

 <https://doi.org/10.24912/ijaeb.v1i3.1050-1061> (<https://doi.org/10.24912/ijaeb.v1i3.1050-1061>)

### THE EFFECTS OF INDEPENDENT COMMISSIONER, MANAGERIAL OWNERSHIP, FOREIGN OWNERSHIP, AND PROFITABILITY ON INTELLECTUAL CAPITAL (<https://journal.untar.ac.id/index.php/ijaeb/article/view/26890>)

Patricia Nikita Yonata, Liana Susanto  
1360-1370

PDF (<https://journal.untar.ac.id/index.php/ijaeb/article/view/26890/16180>)



|  Abstract views: 0 |  Download :0

 <https://doi.org/10.24912/ijaeb.v1i3.1360-1370> (<https://doi.org/10.24912/ijaeb.v1i3.1360-1370>)

### THE DETERMINANTS OF STOCK PRICE VOLATILITY IN PLANTATION INDUSTRY IN INDONESIA DURING 2016-2020 (<https://journal.untar.ac.id/index.php/ijaeb/article/view/26891>)

Resia Margareta Siawan, Hendro Lukman  
1371-1381

PDF (<https://journal.untar.ac.id/index.php/ijaeb/article/view/26891/16181>)



|  Abstract views: 0 |  Download :0

 <https://doi.org/10.24912/ijaeb.v1i3.1371-1381> (<https://doi.org/10.24912/ijaeb.v1i3.1371-1381>)

### THE IMPACT OF TAX AVOIDANCE, PROFITABILITY, LEVERAGE, AND COMPANY SIZE ON EARNINGS MANAGEMENT (<https://journal.untar.ac.id/index.php/ijaeb/article/view/26892>)

Yasa Mulya Kusuma, Hendro Lukman  
1382-1394

PDF (<https://journal.untar.ac.id/index.php/ijaeb/article/view/26892/16182>)



|  Abstract views: 0 |  Download :0

 <https://doi.org/10.24912/ijaeb.v1i3.1382-1394> (<https://doi.org/10.24912/ijaeb.v1i3.1382-1394>)

### THE DETERMINANTS OF TIMELINESS SUBMISSION OF FINANCIAL STATEMENTS IN THE COVID-19 ERA (<https://journal.untar.ac.id/index.php/ijaeb/article/view/26893>)

Catherine Estevania, Herlin Tundjung Setijaningsih  
1395-1411

PDF (<https://journal.untar.ac.id/index.php/ijaeb/article/view/26893/16183>)



|  Abstract views: 0 |  Download :0

 <https://doi.org/10.24912/ijaeb.v1i3.1395-1411> (<https://doi.org/10.24912/ijaeb.v1i3.1395-1411>)

### ANALYSIS ON THE STRATEGY AND IMPLEMENTATION OF DIGITAL TECHNOLOGY IN THE XYZ COMPANY (<https://journal.untar.ac.id/index.php/ijaeb/article/view/26894>)

Septihani Michella Wijaya, Bellinda Budiman, Livia Johan, Margaret Laurent, Mei le  
1412-1424

PDF (<https://journal.untar.ac.id/index.php/ijaeb/article/view/26894/16184>)



|  Abstract views: 0 |  Download :0

 <https://doi.org/10.24912/ijaeb.v1i3.1412-1424> (<https://doi.org/10.24912/ijaeb.v1i3.1412-1424>)

### DRIVERS OF NEW VENTURE DIGITALIZATION AMONG MALAYSIAN SMES: A CONCEPTUAL MODEL (<https://journal.untar.ac.id/index.php/ijaeb/article/view/26895>)

Tay Lee Chin, Yeo Chu May Amy, Hong Chien Tan, Babatunde Musiliu Abina  
1425-1440

PDF (<https://journal.untar.ac.id/index.php/ijaeb/article/view/26895/16185>)

|  Abstract views: 0 |  Download :0



 <https://doi.org/10.24912/ijaeb.v1i3.1425-1440> (<https://doi.org/10.24912/ijaeb.v1i3.1425-1440>)

### THE ADOPTION OF GOOD CORPORATE GOVERNANCE PRINCIPLES HEIGHTEN MOMENTUM ON EMPLOYEE COMMITMENT (<https://journal.untar.ac.id/index.php/ijaeb/article/view/26896>)

Amy Yeo Chu May1, Ngo Jia Qi, Felizia Arni Rudiawarni  
1441-1456



PDF (<https://journal.untar.ac.id/index.php/ijaeb/article/view/26896/16186>)



 Abstract views: 0 |  Download :0

 <https://doi.org/10.24912/ijaeb.v1i3.1441-1456> (<https://doi.org/10.24912/ijaeb.v1i3.1441-1456>)

### THE IMPACT OF BOARD OF DIRECTOR'S DIVERSITY ON FINANCIAL PERFORMANCE AMONG BANKING COMPANIES LISTED ON IDX (<https://journal.untar.ac.id/index.php/ijaeb/article/view/26897>)

Herni Kurniawati, Sriwati Sriwati  
1457-1473

PDF (<https://journal.untar.ac.id/index.php/ijaeb/article/view/26897/16187>)



 Abstract views: 0 |  Download :0

 <https://doi.org/10.24912/ijaeb.v1i3.1457-1473> (<https://doi.org/10.24912/ijaeb.v1i3.1457-1473>)

### ANALYSIS OF FACTORS AFFECTING DIVIDEND DISTRIBUTED WITH COMPANY SIZE AS MODERATING VARIABLE (<https://journal.untar.ac.id/index.php/ijaeb/article/view/26898>)

Rini Tri Hastuti, Dian Octaviani  
1474-1485

PDF (<https://journal.untar.ac.id/index.php/ijaeb/article/view/26898/16188>)



 Abstract views: 0 |  Download :0

 <https://doi.org/10.24912/ijaeb.v1i3.1474-1485> (<https://doi.org/10.24912/ijaeb.v1i3.1474-1485>)

### FACTORS AFFECTING SUSTAINABILITY REPORT DISCLOSURE AMONG IDX-LISTED MINING COMPANIES (<https://journal.untar.ac.id/index.php/ijaeb/article/view/26899>)

Joevine Angela, Herlin Tundjung Setijaningsih  
1386-1902

PDF (<https://journal.untar.ac.id/index.php/ijaeb/article/view/26899/16189>)



 Abstract views: 0 |  Download :0

 <https://doi.org/10.24912/ijaeb.v1i3.1386-1902> (<https://doi.org/10.24912/ijaeb.v1i3.1386-1902>)

### THE EFFECT OF ENTREPRENEURIAL ORIENTATION AND MARKET ORIENTATION ON JAKARTA'S CULINARY BUSINESS PERFORMANCE (<https://journal.untar.ac.id/index.php/ijaeb/article/view/26900>)

Thalia Fransisca, Lydiawati Soelaiman  
1503-1511

PDF (<https://journal.untar.ac.id/index.php/ijaeb/article/view/26900/16190>)

 Abstract views: 0 |  Download :0



 <https://doi.org/10.24912/ijaeb.v1i3.1503-1511> (<https://doi.org/10.24912/ijaeb.v1i3.1503-1511>)

### THE EFFECT OF SHORT-TERM DEBT, LONG-TERM DEBT, TANGIBILITY, SALES GROWTH, FIRM SIZE, AND DEBT TO ASSET RATIO ON THE PERFORMANCE OF MANUFACTURING

**COMPANIES** (<https://journal.untar.ac.id/index.php/ijaeb/article/view/26901>)

Ellen Agustin Pradana, Elsa Imelda  
1512-1525

PDF (<https://journal.untar.ac.id/index.php/ijaeb/article/view/26901/16191>)



|  Abstract views: 0 |  Download :0

 <https://doi.org/10.24912/ijaeb.v1i3.1512-1525> (<https://doi.org/10.24912/ijaeb.v1i3.1512-1525>)

**INDONESIA'S STOCK MARKET LIQUIDITY: THE IMPACT OF COVID-19 PANDEMIC AND SOCIAL DISTANCING** (<https://journal.untar.ac.id/index.php/ijaeb/article/view/26902>)

Felicia Sharyn Yap, Elsa Imelda  
1526-1536

PDF (<https://journal.untar.ac.id/index.php/ijaeb/article/view/26902/16192>)



|  Abstract views: 0 |  Download :0

 <https://doi.org/10.24912/ijaeb.v1i3.1526-1536> (<https://doi.org/10.24912/ijaeb.v1i3.1526-1536>)

**COMPARATIVE ANALYSIS OF COMPANY PERFORMANCE BEFORE AND AFTER MERGERS AND ACQUISITIONS IN COMPANY LISTED ON IDX 2018-2021** (<https://journal.untar.ac.id/index.php/ijaeb/article/view/26903>)

Jon Edrick, Andi Wijaya  
1537-1547

PDF (<https://journal.untar.ac.id/index.php/ijaeb/article/view/26903/16193>)



|  Abstract views: 0 |  Download :0

 <https://doi.org/10.24912/ijaeb.v1i3.1537-1547> (<https://doi.org/10.24912/ijaeb.v1i3.1537-1547>)

**THE EFFECT OF COMPENSATION AND WORK MOTIVATION ON DRIVER PERFORMANCE MEDIATED BY ORGANIZATIONAL COMMITMENT** (<https://journal.untar.ac.id/index.php/ijaeb/article/view/26904>)

Ni Kadek Nonik Rasminingsih, I Komang Oka Permadi, I Komang Suryadnya Diputra, I Made Aditya Wardana  
1548-1556

PDF (<https://journal.untar.ac.id/index.php/ijaeb/article/view/26904/16194>)



|  Abstract views: 0 |  Download :0

 <https://doi.org/10.24912/ijaeb.v1i3.1548-1556> (<https://doi.org/10.24912/ijaeb.v1i3.1548-1556>)

**THE IMPACT OF BRAND REPUTATION AND MARKETING TOOLS ON PURCHASING INTENTIONS -CARE PRODUCTS AS AN EXAMPLE** (<https://journal.untar.ac.id/index.php/ijaeb/article/view/26905>)

Linda Lin-Chin Lin, Ghung-Hsin Yang, Yan-Ting Wang, Paula Tjatoerwidya Anggarina, Agustinus Purna Irawan  
1557-1564

PDF (<https://journal.untar.ac.id/index.php/ijaeb/article/view/26905/16195>)



 Abstract views: 0 |  Download :0

 <https://doi.org/10.24912/ijaeb.v1i3.1557-1564> (<https://doi.org/10.24912/ijaeb.v1i3.1557-1564>)

### PROPOSING INNOVATION MANAGEMENT MODEL IN LARGE CORPORATION (<https://journal.untar.ac.id/index.php/ijaeb/article/view/26906>)

Aloysius Budi Santoso, Agustinus Purna Irawan, Eko Suhartanto  
1565-1573

[PDF \(https://journal.untar.ac.id/index.php/ijaeb/article/view/26906/16196\)](https://journal.untar.ac.id/index.php/ijaeb/article/view/26906/16196)



 Abstract views: 0 |  Download :0

 <https://doi.org/10.24912/ijaeb.v1i3.1565-1573> (<https://doi.org/10.24912/ijaeb.v1i3.1565-1573>)

### THE ROLE OF SUBJECTIVE NORMS TO PREDICT EXPERIMENTAL BEHAVIOR THROUGH INTENTION OF SME OWNER IN JAKARTA (<https://journal.untar.ac.id/index.php/ijaeb/article/view/26907>)

Frangky Selamat  
1574-1580

[PDF \(https://journal.untar.ac.id/index.php/ijaeb/article/view/26907/16197\)](https://journal.untar.ac.id/index.php/ijaeb/article/view/26907/16197)



 Abstract views: 0 |  Download :0

 <https://doi.org/10.24912/ijaeb.v1i3.1574-1580> (<https://doi.org/10.24912/ijaeb.v1i3.1574-1580>)

### THE IMPACT OF LEMONILO GREEN MARKETING ON PURCHASE INTENTION (<https://journal.untar.ac.id/index.php/ijaeb/article/view/26908>)

Ricarhdus Rikky Riyanto, Ongky Alex Sander, Yenli Megawati, Rickel Arial Kaisar Elim, Cerlysia Cerlysia  
1581-1589

[PDF \(https://journal.untar.ac.id/index.php/ijaeb/article/view/26908/16198\)](https://journal.untar.ac.id/index.php/ijaeb/article/view/26908/16198)



 Abstract views: 0 |  Download :0

 <https://doi.org/10.24912/ijaeb.v1i3.1581-1589> (<https://doi.org/10.24912/ijaeb.v1i3.1581-1589>)

### THE IMPACT OF INNOVATION, BRAND IMAGE, AND SOCIAL MEDIA MARKETING ON MENANTEA PURCHASE INTENTION (<https://journal.untar.ac.id/index.php/ijaeb/article/view/26909>)

Toni Frandi, Ongky Alex Sander<sup>1</sup>, Ferdinandus Soesilo, Fahrul Riza, Eric Sidarta  
1590-1602

[PDF \(https://journal.untar.ac.id/index.php/ijaeb/article/view/26909/16199\)](https://journal.untar.ac.id/index.php/ijaeb/article/view/26909/16199)



 Abstract views: 0 |  Download :0

 <https://doi.org/10.24912/ijaeb.v1i3.1590-1602> (<https://doi.org/10.24912/ijaeb.v1i3.1590-1602>)

### THE EFFECT OF EMPATHY AND PREVIOUS EXPERIENCES ON SOCIAL ENTREPRENEUR BEHAVIOR WITH SELF-EFFICACY, OUTCOME EXPECTATIONS AND SOCIAL SUPPORT AS MEDIATOR IN JAKARTA (<https://journal.untar.ac.id/index.php/ijaeb/article/view/26910>)



Valerie Sephira, Frangky Selamat

1603-1612

[PDF \(https://journal.untar.ac.id/index.php/ijaeb/article/view/26910/16200\)](https://journal.untar.ac.id/index.php/ijaeb/article/view/26910/16200)|  Abstract views: 0 |  Download :0 <https://doi.org/10.24912/ijaeb.v1i3.1603-1612> (<https://doi.org/10.24912/ijaeb.v1i3.1603-1612>)**THE DETERMINANTS OF COMPANY'S FINANCIAL DISTRESS** (<https://journal.untar.ac.id/index.php/ijaeb/article/view/26911>)



Jonnardi Jonnardi, Nurainun Bangun, Khairina Natsir

1613-1624

[PDF \(https://journal.untar.ac.id/index.php/ijaeb/article/view/26911/16201\)](https://journal.untar.ac.id/index.php/ijaeb/article/view/26911/16201)|  Abstract views: 0 |  Download :0 <https://doi.org/10.24912/ijaeb.v1i3.1613-1624> (<https://doi.org/10.24912/ijaeb.v1i3.1613-1624>)**THE MEDIATING ROLE OF ENTREPRENEURIAL SELF-EFFICACY IN THE EFFECTS OF NEED FOR ACHIEVEMENT AND SELF-CREATIVITY ON ENTREPRENEURIAL INTENTION AMONG WOMEN ENTREPRENEURS IN JAKARTA** (<https://journal.untar.ac.id/index.php/ijaeb/article/view/26942>)



Jessyca Vallerine, Sarwo Edy Handoyo

1625-1639

[PDF \(https://journal.untar.ac.id/index.php/ijaeb/article/view/26942/16232\)](https://journal.untar.ac.id/index.php/ijaeb/article/view/26942/16232)|  Abstract views: 0 |  Download :0 <https://doi.org/10.24912/ijaeb.v1i3.1625-1639> (<https://doi.org/10.24912/ijaeb.v1i3.1625-1639>)**TRANSFORMATION OF MARKETING ROLE STRATEGY IN REALIZING PURCHASE INTENTION** (<https://journal.untar.ac.id/index.php/ijaeb/article/view/26943>)



Jubery Marwan, Paiman Raharjo, T. Herry Rachmatsyah, Zahera Mega

1640-1653

[PDF \(https://journal.untar.ac.id/index.php/ijaeb/article/view/26943/16233\)](https://journal.untar.ac.id/index.php/ijaeb/article/view/26943/16233)|  Abstract views: 0 |  Download :0 <https://doi.org/10.24912/ijaeb.v1i3.1640-1653> (<https://doi.org/10.24912/ijaeb.v1i3.1640-1653>)**VALIDATING FACTORS AFFECTING PEOPLE'S INTENTION TO USE FINANCE COMPANIES' SERVICES IN INDONESIA** (<https://journal.untar.ac.id/index.php/ijaeb/article/view/26944>)

Keni Keni , Nicholas Wilson, Alexander Alexander



1654-1668

[PDF \(https://journal.untar.ac.id/index.php/ijaeb/article/view/26944/16234\)](https://journal.untar.ac.id/index.php/ijaeb/article/view/26944/16234)|  Abstract views: 0 |  Download :0 <https://doi.org/10.24912/ijaeb.v1i3.1654-1668> (<https://doi.org/10.24912/ijaeb.v1i3.1654-1668>)**FACTORS INFLUENCING CUSTOMER LOYALTY TOWARD MIXUE ICE CREAM AND TEA SHOP**

**IN JAKARTA (https://journal.untar.ac.id/index.php/ijaeb/article/view/26945)**

Jacky Sona Putra, Cokki Cokki  
1669-1680

PDF (https://journal.untar.ac.id/index.php/ijaeb/article/view/26945/16235)



|  Abstract views: 0 |  Download :0

 <https://doi.org/10.24912/ijaeb.v1i3.1669-1680> (https://doi.org/10.24912/ijaeb.v1i3.1669-1680)

**FACTORS AFFECTING PURCHASE INTENTION OF THE ICE CREAM INDUSTRY (https://journal.untar.ac.id/index.php/ijaeb/article/view/26946)**

Stefanni Tjayadi, Miharni Tjokrosaputro, Nadia Ariniputri  
1681-1693

PDF (https://journal.untar.ac.id/index.php/ijaeb/article/view/26946/16236)



|  Abstract views: 0 |  Download :0

 <https://doi.org/10.24912/ijaeb.v1i3.1681-1693> (https://doi.org/10.24912/ijaeb.v1i3.1681-1693)

**FACTOR THAT AFFECTS REPURCHASE INTENTION AMONG SHOPEE CUSTOMERS IN WEST JAKARTA (SATISFACTION AS A MEDIATOR) (https://journal.untar.ac.id/index.php/ijaeb/article/view/26947)**

Chyntia Anggelina, Tommy Setiawan Ruslim  
1694-1705

PDF (https://journal.untar.ac.id/index.php/ijaeb/article/view/26947/16237)



|  Abstract views: 0 |  Download :0

 <https://doi.org/10.24912/ijaeb.v1i3.1694-1705> (https://doi.org/10.24912/ijaeb.v1i3.1694-1705)

**THE EFFECTIVENESS OF FUNERAL RETRIBUTION PAYMENTS IN DKI JAKARTA (https://journal.untar.ac.id/index.php/ijaeb/article/view/26949)**

Hendi Prihanto, Usmar Usmar , Selfiani Selfiani , Yudhistira Adwimurti  
1706-1721

PDF (https://journal.untar.ac.id/index.php/ijaeb/article/view/26949/16238)



|  Abstract views: 0 |  Download :0

 <https://doi.org/10.24912/ijaeb.v1i3.1706-1721> (https://doi.org/10.24912/ijaeb.v1i3.1706-1721)

**THE INFLUENCE OF INVESTMENT MOTIVATION, INVESTMENT KNOWLEDGE, AND FINANCIAL LITERACY ON INVESTMENT INTEREST (https://journal.untar.ac.id/index.php/ijaeb/article/view/26951)**

Angela Eunike Fortunatus, Ary Satria Pamungkas  
1722-1731

PDF (https://journal.untar.ac.id/index.php/ijaeb/article/view/26951/16240)



|  Abstract views: 0 |  Download :0

 <https://doi.org/10.24912/ijaeb.v1i3.1722-1731> (https://doi.org/10.24912/ijaeb.v1i3.1722-1731)

THE INFLUENCE OF FINANCIAL LITERACY, REGRET AVERSION BIAS, AND OVERCONFIDENCE ON INVESTMENT DECISION (<https://journal.untar.ac.id/index.php/ijaeb/article/view/26952>)

Angela Tiffany1, Ary Satria Pamungkas  
1732-1739

PDF (<https://journal.untar.ac.id/index.php/ijaeb/article/view/26952/16242>)



|  Abstract views: 0 |  Download :0

 <https://doi.org/10.24912/ijaeb.v1i3.1732-1739> (<https://doi.org/10.24912/ijaeb.v1i3.1732-1739>)

UNDERSTANDING RELATIONSHIP INTELLECTUAL CAPITAL AND FINANCIAL PERFORMANCE ON HEALTHCARE SECTOR (<https://journal.untar.ac.id/index.php/ijaeb/article/view/26954>)

Jovita Jovita , Kartika Nuringsih  
1740-1748

PDF (<https://journal.untar.ac.id/index.php/ijaeb/article/view/26954/16244>)



|  Abstract views: 0 |  Download :0

 <https://doi.org/10.24912/ijaeb.v1i3.1740-1748> (<https://doi.org/10.24912/ijaeb.v1i3.1740-1748>)

THE INFLUENCE OF BRAND INTERACTIVITY, INVOLVEMENT, SOCIAL MEDIA CBE ON LOYALTY: TRUST AS A MEDIATION VARIABLE (<https://journal.untar.ac.id/index.php/ijaeb/article/view/26956>)

Febrienne Clarissa Cahyadi, Hetty Karunia Tunjungsari  
1749-1757

PDF (<https://journal.untar.ac.id/index.php/ijaeb/article/view/26956/16246>)



|  Abstract views: 0 |  Download :0

 <https://doi.org/10.24912/ijaeb.v1i3.1749-1757> (<https://doi.org/10.24912/ijaeb.v1i3.1749-1757>)

THE IMPACT OF WORK STRESS ON CYBERLOAFING BEHAVIOUR IN TRAVEL COMPANY EMPLOYEE'S POST COVID-19 PANDEMIC WITH SELF-CONTROL AS MEDIATING ROLE (<https://journal.untar.ac.id/index.php/ijaeb/article/view/26958>)

Yenita Yenita , Ashari Rahmadi  
1758-1768

PDF (<https://journal.untar.ac.id/index.php/ijaeb/article/view/26958/16247>)



|  Abstract views: 0 |  Download :0

 <https://doi.org/10.24912/ijaeb.v1i3.1758-1768> (<https://doi.org/10.24912/ijaeb.v1i3.1758-1768>)

INVESTIGATING THE IMPACT OF FRIENDS, CELEBRITIES, OPINION LEADERS, SOCIAL VALUE AND PERSONAL VALUE ON PURCHASE INTENTION OF LUXURY FASHION CONSUMERS IN JAKARTA (<https://journal.untar.ac.id/index.php/ijaeb/article/view/26959>)

Nesya Verdelia Valeta, Tommy Setiawan Ruslim  
1769-1781

PDF (<https://journal.untar.ac.id/index.php/ijaeb/article/view/26959/16249>)



|  Abstract views: 0 |  Download :0

 <https://doi.org/10.24912/ijaeb.v1i3.1769-1781> (<https://doi.org/10.24912/ijaeb.v1i3.1769-1781>)

### THE INFLUENCE OF INTELLECTUAL INTELLIGENCE AND EMOTIONAL INTELLIGENCE ON EMPLOYEE PERFORMANCE MEDIATED BY JOB SATISFACTION (<https://journal.untar.ac.id/index.php/ijaeb/article/view/26961>)

Gratiani Gilliani, Mukti Rahardjo  
1782-1793

PDF (<https://journal.untar.ac.id/index.php/ijaeb/article/view/26961/16250>)



|  Abstract views: 0 |  Download :0

 <https://doi.org/10.24912/ijaeb.v1i3.1782-1793> (<https://doi.org/10.24912/ijaeb.v1i3.1782-1793>)

### STRATEGIC ANALYSIS OF PT. KMDS, TBK. (INDONESIA'S MONIN SYRUPS DISTRIBUTOR & IMPORTER) (<https://journal.untar.ac.id/index.php/ijaeb/article/view/26963>)

Steven Lukman, Haris Maupa  
1794-1804

PDF (<https://journal.untar.ac.id/index.php/ijaeb/article/view/26963/16252>)



|  Abstract views: 0 |  Download :0

 <https://doi.org/10.24912/ijaeb.v1i3.1794-1804> (<https://doi.org/10.24912/ijaeb.v1i3.1794-1804>)

### PURCHASE DECISIONS ANALYSIS WITH SEVERAL FACTORS (<https://journal.untar.ac.id/index.php/ijaeb/article/view/26965>)

Winda Winda , Haris Maupa  
1805-1815

PDF (<https://journal.untar.ac.id/index.php/ijaeb/article/view/26965/16254>)

|  Abstract views: 0 |  Download :0

 <https://doi.org/10.24912/ijaeb.v1i3.1805-1815> (<https://doi.org/10.24912/ijaeb.v1i3.1805-1815>)

#### TOOLS

use APA style, download here



(<https://csl.mendeley.com/styleInfo/?styleId=http%3A%2F%2Fwww.zotero.org%2Fstyles%2Fapa>)

#### Template



([https://docs.google.com/document/d/1h39XGU5\\_5eMJAXhKGSvEGVhpxMrxwRCF/edit?usp=share\\_link&oid=112826885138839568747&rtpof=true&sd=true](https://docs.google.com/document/d/1h39XGU5_5eMJAXhKGSvEGVhpxMrxwRCF/edit?usp=share_link&oid=112826885138839568747&rtpof=true&sd=true))

#### PROFILE MENU

Contact

Editorial Team (</index.php/ijaeb/about/editorialTeam>)

Focus and Scope (</index.php/ijaeb/about#focusAndScope>)

Indexing

Web Analytics (<https://statcounter.com/p12907097/summary/>)

View My Stats (<https://statcounter.com/p12844469/?guest=1>)

#### ISSN

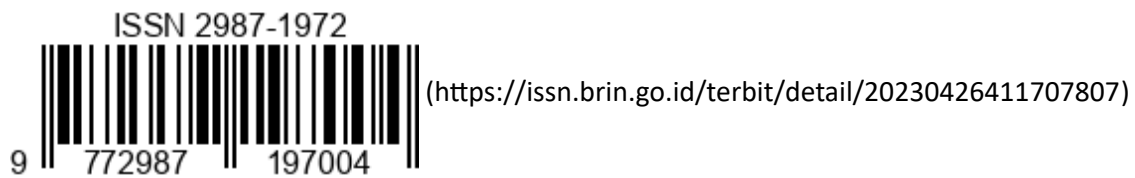

(<https://issn.brin.go.id/terbit/detail/20230426411707807>)

ISSN PUSAT NASIONAL ISSN INDONESIA (<https://issn.brin.go.id/terbit/detail/20230426411707807>)

Indexed by :



([https://scholar.google.com/citations?hl=id&user=UuFn-joAAAAJ&view\\_op=list\\_works&authuser=2&gmla=AOV7GLMmf1WMkuBiJMC0LiHjEROH-c\\_rOjP\\_5mNgA2HCGL6-7p0men-j8wm22Zu3MGLdhGHqGsTFvVj60JgtCV4](https://scholar.google.com/citations?hl=id&user=UuFn-joAAAAJ&view_op=list_works&authuser=2&gmla=AOV7GLMmf1WMkuBiJMC0LiHjEROH-c_rOjP_5mNgA2HCGL6-7p0men-j8wm22Zu3MGLdhGHqGsTFvVj60JgtCV4))

view\_op=list\_works&authuser=2&gmla=AOV7GLMmf1WMkuBiJMC0LiHjEROH-c\_rOjP\_5mNgA2HCGL6-7p0men-j8wm22Zu3MGLdhGHqGsTFvVj60JgtCV4)



(<https://www.mendeley.com/profiles/jurnal-muara-ilmu-ekonomi->



dan/publications/)



Dimensions

(https://app.dimensions.ai/discover

/publication?search\_mode=content&amp;search\_text=10.24912%2Fijaeb&amp;search\_type=kws&amp;

search\_field=text\_search)



(https://portal.issn.org/resource

/ISSN/2987-1972)



(https://garuda.kemdikbud.go.id/journal/view/31672)



(https://journals.indexcopernicus.com/search/details?id=128371&amp;

lang=en)



(http://untar.ac.id/)

**UNTAR**  
Universitas Tarumanagara

Graduate Program of Universitas Tarumanagara

# Platform & workflow by OJS / PKP

  
(<https://journal.untar.ac.id/index.php/ijaeb/about/aboutThisPublishingSystem>)

# **THE EFFECT OF CAPITAL STRUCTURE, LIQUIDITY, PROFITABILITY, ACTIVITY, AND INSTITUTIONAL OWNERSHIP ON COMPANY VALUE AMONG MANUFACTURING COMPANIES LISTED ON INDONESIA STOCK EXCHANGE DURING 2017-2022**

**Christina Tania<sup>1</sup>, Merry Susanti<sup>1\*</sup>**

<sup>1</sup>Faculty of Economics and Business, Universitas Tarumanagara, Jakarta - Indonesia  
*\*Email: merrys@fe.untar.ac.id*

*Submitted: 03-04-2023, Revised: 08-06-2023, Accepted: 20-07-2023*

---

## **ABSTRACT**

*The value of a company that go public reflects the market price of the company's stocks. With the development of the company for the better, it will certainly affect the value of the company which will also increase. This study aimed at determining the effect of Debt to Equity Ratio (DER), Current Ratio (CR), Return on Equity (ROE), Total Assets Turnover (TATO), and Institutional Ownership (INST) on the Value of Manufacturing Companies listed in Indonesia Stock Exchange for the period 2017-2020. The sampling technique in this study used purposive sampling so that 56 companies were obtained. The research analysis method used was Panel Data Regression. The results showed that DER had a positive and significant effect on firm value, while CR, ROE, TATO, and INST had no influence on firm value.*

**Keywords:** *Debt to Equity Ratio, Current Ratio, Return on Equity, Total Assets Turnover, Institutional Ownership, Price to Book Value*

## **1. INTRODUCTION**

Each company has a different purpose from which the company was founded. The first goal is to get the maximum profit. The second goal is that the company wants to create prosperity for the shareholders of the company. The third goal is that the company wants to maximize the value of the company which is reflected in the value of the company's shares. Every company has the right to choose the main goal that they believe can benefit them.

The value of the company is considered important because it becomes a benchmark for decisions in the investment chosen by potential investors and is related to the prosperity of shareholders. The higher the value of the company, the higher the prosperity of the shareholders [1].

In the manufacturing industry there is tough competition so that it can trigger every company to do the best performance. Through efforts to improve the company's performance is the company's first step to achieve company goals so that the increase in performance is seen positively by investors. This is followed by investment in the company so that the value of the company also increases, and the company's goals can also be achieved and vice versa. Solvency, liquidity, profitability, activity, and institutional ownership ratios were selected as independent variables to see the effect of each independent variable on firm value as the dependent variable. The high stock value reflects the future prospect of the company. The good performance of the company can also increase the confidence of shareholders so that they are willing to invest, and this can increase the value of the company.

Based on research conducted by Chabachib et al. [2] and Kurniasari [3] state that the DER value has a positive effect on PBV. Meanwhile, the research by Lating et al. [4] and Wahyuni & Gani [5] states that DER has a negative effect on PBV. Other researchers such as Jufrizen and Fatin [6] also Suhardjo et al [7] stated that DER has no effect on PBV.

Based on research conducted by Fitri et al. [8] and Jihadi et al. [9] stated that CR values have a positive effect on PBV. Meanwhile, the research by Puspita & Siswanti [10] and [11] Yuliani & Jonnadi states that CR has a negative effect on PBV. Other researchers such as Khairunnisa et al [12] and [3] state that CR has no effect on PBV.

Based on research conducted by Soetjanto and Thamrin [13] and [2] stated that the ROE value has a positive effect on PBV. Meanwhile, research by Zutami et al [14] states that ROE has a negative effect on PBV. Other researchers such as Hirdinis [15] also Johan and Septriani [16] state that ROE has no effect on PBV.

Based on research conducted by Salainti and Sugiono [17] also [12] stated that the TATO value has a positive effect on PBV. Meanwhile, Kurniasari [3] states that TATO has a negative effect on PBV. Other researchers such as [13] state that TATO has no effect on PBV.

Based on research conducted by Nuryono et al [18] also Steven and Suparmun [19] states that the INST value has a positive effect on PBV. Meanwhile, the research by Mastuti and Prastiwi [20] also [7] states that INST has a negative effect on PBV. Other researchers such as Widyaningsih [21] state that INST has no effect on PBV.

Based on the description above, it appears that there are many factors that affect the value of the company. Therefore, this study will examine these factors on firm value with the title "INFLUENCE OF CAPITAL STRUCTURE (DER), LIQUIDITY (CR), PROFITABILITY (ROE), ACTIVITY (TATO), AND INSTITUTIONAL OWNERSHIP (INST) ON COMPANY VALUE (PBV) ON MANUFACTURING COMPANIES LISTED ON IDX PERIOD 2017-2020".

## **Theoretical Review**

### *Trade-off Theory*

This theory shows that the company has an optimal level of debt and adjusts its actual debt level towards the optimal point. If the funding from debt by the company is higher, the risk faced by the company will also be higher [22]. Companies with debt levels that are too high are called overleveraged. Companies with debt levels that are too low are called underleveraged. Trade-off theory is a theory used by companies in financing investment using debt. There are benefits from the tax side on interest payments paid so that it can reduce the amount of taxes paid by the company. There are risks that must be faced by companies due to using too high funding through debt, namely bankruptcy [23].

### *Signaling Theory*

Signaling theory is an action given by the company's management to investors by showing signals or signs regarding the management's assessment of the company's prospects [24]. The signal given by the management can give three meanings. The first signal is a signal related to the company's risk that will be faced by investors. The second signal is the company's returns

for investors. The third signal is a signal that describes the company's prospects in the future. Information or signals provided by management are very essential for businesspeople, especially investors [2].

The information provided by the management is expected to be used by external parties to assess the good or bad condition of the company. Management has more information than investors. This is known as asymmetric information [2]. Signaling theory according to [2] is used to reduce information asymmetry between company management and outside parties such as investors. The information provided presents an overview or record of the company's past, present, and future conditions that can be analyzed through the company's financial statements. The information presented is expected to be relevant, accurate, and complete so that investors can use it as consideration in investment decisions that affect the sustainability of the company.

## **Literature Review**

### *The Effect of Debt to Equity Ratio on Price to Book Value*

The capital structure is able to describe how much the company's financing is through debt and capital [13]. The study states that DER has a positive effect on firm value. The higher the liabilities that are managed properly, the investors can be sure that the company does not act recklessly in debt management. Thus, potential investors want to invest in the company so that the value of the company also increases.

This study is not in line with the research conducted by Lating et al. [4] which states that DER has a negative effect on firm value. The company is considered to have a high dependence, and this becomes a burden for the company. The DER value that is too high causes the interest of investors to decrease because there are concerns that the company will not be able to pay its obligations so that the value of the company can decrease. Other researchers, namely Puspita and Siswanti [10] stated that the DER value did not affect PBV. The DER value that has no effect means that the rise and fall of the DER value has no impact on the value of the company.

### *The Effect Current Ratio on Price to Book Value*

Liquidity Ratio is a ratio that measures the company's ability to meet its short-term debt obligations as they mature [13]. Jihadi et al. [9] stated that CR had a positive effect on PBV. The higher the CR value, the company is able to meet its obligations through its current assets, so that it will increase public confidence that the company is responsible for its obligations. It will affect the increase in the value of the company Yuliani and Jonadi [11] that the higher the CR, the value of the company will decrease because it is considered that the company does not use cash as well as possible so it must use the assets it has. Another study conducted by Kurniasari [3] stated that the high and low CR value cannot affect the PBV value because the CR value cannot be fully used to assess the condition of the company. Using CR as a determinant of firm value, it is considered to only describe short-term credit risk and the efficiency of using short-term assets.

### *The Effect Return on Equity on Price to Book Value*

Profitability ratio is a ratio that describes the company's ability to generate profits within a certain period and the effectiveness of the company in carrying out company operations [13]. According to [13], ROE has a positive effect on PBV. The higher the ROE value, the more

efficient the use of own capital and it is considered by investors that the company's performance is getting better so that the value of the company can increase.

Another opinion from researchers Zutami et al. [14] stated that ROE has a negative effect on PBV, which means that the company has not succeeded in getting a net profit that can be used to restore shareholder equity. This condition indicates that the company's performance is not getting better. Another researcher's opinion, namely Hirdinis [15] states that ROE has no effect on PBV because ROE is not a strong factor that makes the value of the company increase or decrease.

#### *The Effect Total Assets Turnover on Price to Book Value*

Activity ratio is the ratio used to measure the effectiveness of the company in using its assets [13]. Research conducted by Lating et al. [4] stated that TATO has a positive effect on firm value. The higher the value of the TATO, the company is considered to be more effective in using the company's assets in obtaining profits from the sale of the company. The higher the value of the TATO is also considered the higher the utilization of assets which of course is appreciated by the market so that the higher the company's stock price also has an impact on the high value of the company.

Research by Soetjanto and Thamrin [13] states that TATO has no effect on PBV. Another study conducted by Kurniasari [3] stated that TATO has a negative effect on PBV. The negative effect of the TATO value on PBV means that a lot of inventory or company assets are idle so that the company works ineffectively so that the value of the company decreases.

#### *The Effect Institutional Ownership on Price to Book Value*

Mastuti and Prastiwi [20] stated that INST had a positive effect on PBV. The increase in institutional ownership encourages management to do their best to meet the demands of shareholders. Management performance that maximizes the needs of shareholders will make other institutions also want to invest in the company in order to benefit from the results of the good performance of the company's management. This condition will increase the value of the company.

Another researcher, namely Suharjo et al. [7] stated the opposite, namely, INST had a negative effect on PBV. This is because the majority share ownership held by the institution will make the institution try to influence the management to prioritize the interests of the institutional shareholder so that it can harm the company's operations and have an impact on other investors who are not interested in investing so that the value of the company decreases. Another researcher, Widyaningsih [21] stated that INST had no effect on firm value. This can happen because the majority shareholders are not from institutions so that management does not make the interests of institutional shareholders the main focus. This shows that INST has no effect on firm value.

### **Research Hypothesis**

DER is a ratio that can be used to measure firm value. The DER value reflects the company's ability to meet its obligations by using its own capital so that investor confidence can increase. The trade-off theory states that the DER position is below the optimal point, so any additional debt will increase the value of the company. Investors' assessment of a company that has an

optimum DER value will be believed to have the ability to fulfil the obligations of the company. This trust will increase the confidence for investors to invest their capital so that these conditions can increase the value of the company.

**Ha<sub>1</sub>**: DER has a positive and significant effect on PBV.

CR is used to measure the company's ability to meet current liabilities using the company's current assets. In line with the signal theory, if CR increases, the company is considered capable of paying all its short-term obligations and illustrates the availability of sufficient funds to support the company's operational activities. This gives a good signal to investors that the company has healthy finances and makes investors interested in investing their capital. This makes the value of the company also increase.

**Ha<sub>2</sub>**: CR has a positive and significant effect on PBV.

ROE is used to measure the company's ability to earn profits for the company with its own capital. The COVID-19 pandemic has caused many companies to experience a decline in profitability. This condition is in line with signal theory, where the decline in profitability figures as measured by ROE gives a signal to investors that the company is not doing well, it could even be heading for bankruptcy. This condition will be seen as detrimental to the parties so that they are reluctant to invest, even many investors who immediately withdraw capital from the company so as not to experience greater losses. This causes the value of the company to decrease.

**Ha<sub>3</sub>**: ROE has a negative and significant effect on PBV.

TATO can reflect the company's performance through the level of efficiency and effectiveness of the company in asset turnover. Signal theory says that a high TATO value gives a signal that the company's effectiveness is getting better. This is considered a good signal for investors so that it can attract investors to invest in the company and increase the value of the company.

**Ha<sub>4</sub>**: TATO has a positive and significant effect on PBV.

INST is considered capable of increasing supervision of management so that there are no actions that are considered to only benefit the management but pay attention to the interests of shareholders. The higher the INST value indicates that the supervision of the management is getting tighter. Signaling theory shows that an increase in the value of INST gives a positive signal to investors because the management has managed to perform well so that it benefits shareholders. This condition will attract investors to invest their capital in the company so that the share price and share value will increase.

**Ha<sub>5</sub>**: INST has a positive and significant effect on PBV.

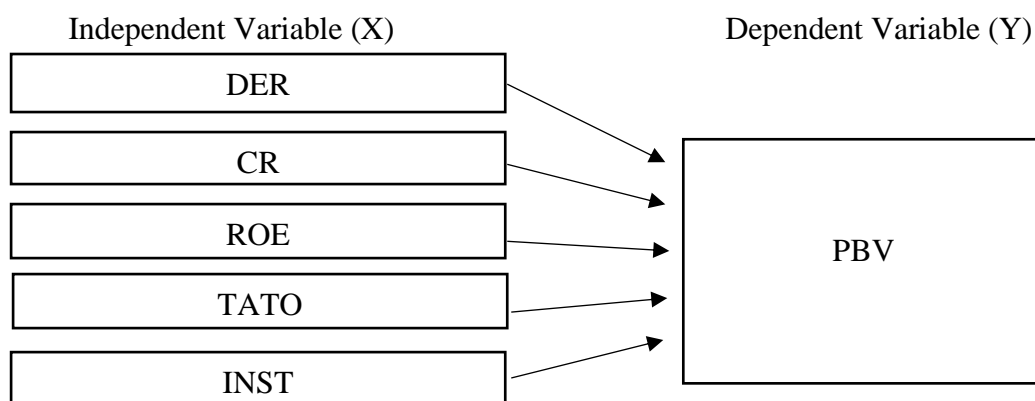

**Figure 1** Research Framework

## 2. RESEARCH METHODS

This study uses a descriptive research design with secondary data obtained from the website [www.idx.co.id](http://www.idx.co.id) and the official websites of related companies. The sample selection technique used purposive sampling and then processed using EViews 9 software. The criteria selected in the sample selection were 1) Manufacturing companies listed on the IDX period 2017-2020, 2) Manufacturing companies that IPO period 2017-2020, 3) Companies manufacturing companies that are not delisted period 2017-2020, 4) Manufacturing companies that present financial statements ending on December 31 during period 2017-2020, 5) Manufacturing companies that earn profits period 2017-2020, 6) Manufacturing companies that have share ownership institutional period 2017-2020. In this research data analysis, there are 174 samples and using panel data regression.

**Table 1.** Research Variables

Variable	Formula	Scale	Sources
<b>Dependent Variable</b>			
Firm Value	$PBV = \frac{PRICE}{BOOK\ VALUE\ PER\ SHARE}$	Ratio	[6]
<b>Independent Variables</b>			
Solvability	$DER = \frac{TOTAL\ DEBT}{TOTAL\ EQUITY}$	Ratio	[6]
Liquidity	$CR = \frac{CURRENT\ ASSETS}{CURRENT\ LIABILITIES}$	Ratio	[6]
Profitability	$ROE = \frac{EARNING\ AFTER\ TAX}{TOTAL\ EQUITY}$	Ratio	[6]
Activity	$TATO = \frac{SALES}{TOTAL\ ASSETS}$	Ratio	[6]
Institutional Ownership	$INST = \frac{SHARES\ OWNED\ BY\ INSTITUTION}{OUTSTANDING\ SHARES}$	Ratio	[14]

## 3. RESULTS

In the classical assumption test, multicollinearity and heteroscedasticity tests must be carried out. In the multicollinearity test, if the correlation between variables  $< 0.8$ , then the selected



regression model escapes the multicollinearity problem. In the heteroscedasticity test using the ARCH test method. When Prob. Chi-Square on Obs\*R-squared has a value of > 0.05, it can be concluded that the data is homoscedastic. Furthermore, the Chow test and Hausman test were carried out using 224 samples and found a suitable model in this study is the Fixed Effect Model (FEM).

**Table 2.** Data Panel Regression Analysis Results

<b>Dependent Variable: PBV</b>				
<b>Variable</b>	<b>Coefficient</b>	<b>Std. Error</b>	<b>t-Statistics</b>	<b>Prob.</b>
C	-3.734.346	4.340.208	-0.860407	0.3908
DER	3.196.866	0.988398	3.234.393	0.0015
CR	0.00307	0.018745	0.16379	0.8701
ROE	-0.062504	0.471962	-0.132435	0.8948
TATO	0.835672	117.214	0.712946	0.4769
INST	4.327.293	5.845.615	0.740263	0.4602

Source: Data Processed Using EViews 9

Based on the test results above, the following is the equation of the panel data regression model used:  $PBV = -3.734346 + 3.196866 DER + 0.003070 CR - 0.062504 ROE + 0.835672 TATO + 4.327293 INST + \varepsilon$

It is known that the coefficient of DER is 3.196866 with prob. value 0.0015 means that DER has a significant positive effect on firm value, which is supported by this study. If the DER value increases, the company value also increases. While the coefficient of CR is 0.00307 with prob. Value 0.8701 means that CR has no significant effect with a positive direction on firm value supported by this study. If the value of CR increases, then the value of the company does not increase and vice versa.

The results for TATO also show that TATO have no significant effect in a positive direction on firm value. The coefficient of TATO is 0.835672 with prob. Value 0.4769. If the value of TATO has increased, then the value of the company does not increase and also the other way around.

Similar with the results for TATO, INST show that INST have no significant effect in a positive direction on firm value. The coefficient of INST is 4.327.293 with prob. Value 0.4602. If there is an increase or decrease in the value of INST, it does not affect the value of the company. For the coefficient of ROE is -0.062504 with prob. Value 0.8948 means that ROE has no significant effect in a negative direction on firm value.

Adjusted-R-squared has a value of 0.649806, so the data concludes that PBV or the dependent variable (Y) can be explained by the independent variables DER, CR, ROE, TATO, and INST of 64.98%, while the remaining 35.02% can be explained by other variables outside this study. The F test was conducted to assess whether the regression model used was fit between the independent variable and the dependent variable. Based on the test results, the prob. value (F-Statistic) is smaller than 0.05, which is 0.0000. So, it can be said that the regression model used is fit between the independent variable and the dependent variable (Y).

#### **4. CLOSING**

Based on the results of testing each variable, it can be concluded that DER has a positive and significant effect on firm value. This is supported by the trade-off theory which states that DER is able to show that the company is able to meet company funding using its own capital so that it can increase investor confidence to invest and have an impact on increasing company value with the assumption that the DER value is below the optimal point.

Based on the results of testing the second variable, CR, it can be concluded that CR has no significant effect on firm value in a positive direction. This is because the CR variable does not directly affect the value of the company through the company's ability to meet its short-term obligations and the company's effectiveness in managing company assets in generating revenue for the company.

Based on the results of testing the third variable, ROE, it can be concluded that ROE does not have a direct influence on firm value. The ROE variable with a negative direction indicates that the decline in profits reflects a decrease in the company's ability to generate large profits due to the extreme conditions that occurred in 2020, namely Covid-19. The company's profit in 2020 experienced a drastic decline so that the company's value also decreased.

Based on the results of testing the fourth variable, TATO, it can be concluded that TATO does not have a significant effect on firm value in a positive direction. This is because the company does not reflect that the rapid turnover of assets in generating income can affect the value of the company. This happened because the Covid-19 pandemic conditions made companies hold sales behaviour because many companies were more careful about uncollectible receivables when assets were successfully sold to buyers.

Based on the results of testing the fifth variable, INST, it can be concluded that INST has no significant effect on firm value in a positive direction. This is because the INST variable does not directly affect firm value. Institutional ownership is considered capable of increasing investor confidence, but investors' considerations do not only depend on institutional ownership, so the INST test has no significant effect and has a positive direction on PBV.

This study has several limitations. The variables used are only five, the research subjects are only companies with the manufacturing industry sector that have gone public, the research period is limited to only four years from 2017-2020. In future research, it is expected to add research variables such as Return on Assets (ROA), earnings management, firm size, earning per share, cash ratio and others. In addition, extending the research period and expanding the industrial sector are expected to produce more relevant data and be able to describe the actual financial condition of the company.

#### **REFERENCES**

- [1] Jufrizen., & Fatin, I. N. A. (2020). Pengaruh Debt to Equity Ratio, Return on Equity, Return On Assets Dan Ukuran Perusahaan Terhadap Nilai Perusahaan Pada Perusahaan Farmasi. *Jurnal Humaniora*, 4(1), 183-195.
- [2] Chabachib, M., Hersugondo., Ardiana, E., & Pamungkas, I. D. (2020). Analysis of Company Characteristics of Firm Values: Profitability as Intervening Variables. *International Journal of Financial Research*, 11(1), 60-70.

- [3] Kurniasari, E. (2020). Pengaruh Current Ratio, Debt To Equity Ratio, Dan Total Asset Turnover Terhadap Nilai Perusahaan. *Intelektiva: Jurnal Ekonomi, Sosial & Humaniora*, 2(5), 86-95.
- [4] Lating, A. I. S., Ngumar, S., & Mildawati, T. (2019). Pengaruh Kinerja Keuangan terhadap Nilai Perusahaan dengan Sustainability Report sebagai Variabel Moderating. *Jurnal Ekonomi Manajemen-Akuntansi*, 15(1), 129-144.
- [5] Wahyuni, N., & Gani, A. A. (2022). Reviewing the Firm Value in terms of Profit, Debt, and Growth. *Jurnal Manajemen*, XXVI(1), 121-139.
- [6] Jufrizen., & Fatin, I. N. A. (2020). Pengaruh Debt to Equity Ratio, Return On Equity, Return On Assets Dan Ukuran Perusahaan Terhadap Nilai Perusahaan Pada Perusahaan Farmasi. *Jurnal Humaniora*, 4(1), 183-195.
- [7] Suhardjo, Yulianty, S., & Chandra, T. (2021). The Effect of Ownership Structure, Debt Policy, Profitability, and Firm Size on Firm Value. *Lucrum: Jurnal Bisnis Terapan*, 1(1), 148-167.
- [8] Fitri, N., Nurhayati., & Helliana. (2019). Pengaruh Current Ratio dan Struktur Modal terhadap Nilai Perusahaan (Studi Empiris pada Perusahaan Sektor Otomotif yang Terdaftar di Bursa Efek Indonesia (BEI) Periode Tahun 2012-2016). *Prosiding Akuntansi*, 4(2), 816-822.
- [9] Jihadi, M., Vilantika, E., Hashemi S. M., Arifin, Z., Bachtiar, Y., & Sholichah, F. (2021). The Effect of Liquidity, Leverage, and Profitability on Firm Value: Empirical Evidence from Indonesia. *Journal of Asian Finance, Economics and Business*, 8(3), 423-431.
- [10] Puspita, E. A., & Siswanti, I. (2021). Effect of Capital Structure and Liquidation on Firms Value with Profitability as Intervening Variables (Case Study On Property And Real Estate Companies Registered In Indonesia Stock Exchange 2014-2019). *Management Research Studies Journal*, 2(1), 11-27.
- [11] Yuliani, M., & Jonnardi. (2021). Pengaruh Struktur Modal, Profitabilitas, Likuiditas dan Ukuran Perusahaan terhadap Nilai Perusahaan. *Jurnal Multiparadigma Akuntansi*, III(2), 739-747.
- [12] Khairunnisa, T., Taufik., & Thamrin, K. M. H. (2019). Pengaruh Debt to Equity Ratio, Return On Assets, Assets Growth, Current Ratio, dan Total Assets Turnover terhadap Nilai Perusahaan pada Perusahaan Sektor Makanan dan Minuman yang Terdaftar di Bursa Efek Indonesia. *Jembatan*, XIV(1), 31-44.
- [13] Soetjanto, J. R., & Thamrin, H. (2020). Analysis of Factor that Effect Firm Value of Consumer Goods Industry Listed on Indonesia Stock Exchange. *International Journal of Scientific and Research Publications*, 10(5), 1-8.
- [14] Zutami, D. D., Romli, H., & Marnisah, L. (2021). Analisis Pengaruh Struktur Modal, Pertumbuhan Perusahaan dan Profitabilitas terhadap Nilai Perusahaan (Studi Kasus pada Perusahaan Food and Beverages yang Terdaftar di Bursa Efek Indonesia LQ45). *Integritas Jurnal Manajemen Profesional*, 2(1), 71-82.

- [15] Hirdinis, M. (2019). Capital Structure and Firm Size on Firm Value Moderated by Profitability. *International Journal of Economics and Business Administration*, VII(1), 174-191.
- [16] Johan, R. S., & Septariani, D. (2020). Pengaruh Profitabilitas terhadap Nilai Perusahaan Farmasi yang Terdaftar di BEI Periode 2014 Sampai 2018. *Journal of Applied Business and Economics*, 7(2), 261-270.
- [17] Salainti, M. L. I., & Sugiono. (2019). Pengaruh Current Ratio, Total Asset Turnover Dan Debt to Equity Ratio dan Return on Asset terhadap Nilai Perusahaan. *Jurnal Ilmu dan Riset Manajemen*, 8(10), 1-23.
- [18] Nuryono, M., Wijayanti, A., & Samrotun, Y. C. (2019). Pengaruh Kepemilikan Manajerial, Kepemilikan Instiusional, Komisaris Independen, Komite Audit, Serta Kualitas Audit Pada Nilai Perusahaan. *Edunomika*, 3(1), 199-212.
- [19] Steven, & Suparmun, H. (2019). Faktor yang Memengaruhi Nilai Perusahaan Non-Keuangan di Bursa Efek Indonesia. *Jurnal Bisnis dan Akuntansi*, 21(1a-2), 131-140.
- [20] Mastuti, A. N., & Prastiwi, D. (2021). Pengaruh Kepemilikan Intiusional dan Ukuran Dewan terhadap Nilai Perusahaan Melalui Profitabilitas. *Jurnal PETA*, 6(2), 222-238.
- [21] Widyaningsih, D. (2018). Kepemilikan Manajerial, Kepemilikan Instiusional, Komisaris Independen, Serta Komite Audit Pada Nilai Perusahaan Dengan Pengungkapan CSR sebagai Variabel Moderating dan Firm Size sebagai Variabel Kontrol. *Jurnal Akuntansi dan Pajak*, 19(1), 38-52.
- [22] Mardiyati, U., Ahmad, G. N., & Putri, R. (2012). Pengaruh Kebijakan Dividen, Kebijakan Hutang dan Profitabilitas terhadap Nilai Perusahaan Manufaktur yang Terdaftar di Bursa Efek Indonesia (BEI) Periode 2005-2010. *Jurnal Riset Manajemen Sains Indonesia (JRMSI)*, 3(1), 1-17.
- [23] Umdiana, N., & Sari, D. L. (2020). Analisis Keputusan Pendanaan terhadap Struktur Modal Melalui Trade Off Theory. *Jurnal Ilmiah Akuntansi Universitas Pamulang*, 8(2), 143-155.
- [24] Brigham, E. F., & Houston, J. F. (2014). *Dasar – Dasar Manajemen Keuangan Edisi 11*. Jakarta: Salemba Empat.