

Effect of Conflict, Job Satisfaction, and Stress on Medical Staff Performance (Study in the Health Facilities, West Jakarta)

Dewi Sri Haryati
Master of Management Program
Universitas Tarumanagara
Jakarta
dewisriharyari88@gmail.com

Rezi Erdiansyah
Faculty of Economics
Universitas Tarumanagara
Jakarta
rezie@fikom.untar.ac.id

Abstract— *This study aims to determine the effect of work conflict, job satisfaction and work stress on the performance of medical personnel. The population in this study were medical personnel including doctors, nurses, midwives, nutritionists, laboratory analysts, radiographers, and pharmacists. This research was limited to respondents of medical personnel who worked in Health Care Facilities in the West Jakarta Region. The Sampling method uses purposive sampling with a non-random sampling technique, as many as 205 respondents. The method of data collection is done by distributing questionnaires online. Data processing uses software Lisrel 22 for structural equation model (SEM). The results of the research hypothesis show there are significant effects of conflict, job satisfaction and work stress on the performance of medical personnel. Of the three variables, which most influence the performance of medical personnel is the variable job satisfaction.*

Keywords: *work conflict, job satisfaction, job stress, performance*

I. INTRODUCTION

The success of health services depends on the participation of medical and medical support in providing quality care for patients (Potter & Perry in Suroso, [1]). In this case, the existence of medical personnel is like 24-hour nurses serving patients, and also related to the number of nurses and midwives

who dominate health workers in a health service facility, which is around 40-60% ([18] in Suroso, [1]). Human resources in Health Service Facilities that often interact with patients are medical and medical support, so the importance of the quality level of services carried out by medical personnel and medical support is assessed as one indicator of good or bad quality of health services [2]. Therefore, internal conflicts need to be avoided to maintain harmony and good relations between fellow medical personnel in an effort to improve the quality of service patients. There are three factors that need attention in managing the performance of medical personnel, namely work conflict, job satisfaction and work stress.

There are two basic type of conflict, is task conflict and relationship conflict that results in employees or employees in an organization having disagreements and also conflicts and can lead to problems that will arise in the work environment [3]. Job satisfaction refers to the general attitude of employees to their work [4]. As a general, a person with high job satisfaction will like his job, so that shows a work is very important to determine one's job satisfaction [5]. Stress is a condition of an individual who experiences tension because of that can influence and these conditions can be obtained from within a self and form the surrounding environment. An individual's response to stressors depends on personality, available resources to stressors depends on personality, and the context in which

stress occurs [6]. Ivancevich, et al. ([11] in Nur, [6]) said, from an the person's perspective, stress can be described as feeling tense, anxious or worried, all feelings are manifestations of stressful experiences, a complex programmed to perceive threats that can generate positive results or negative. This means that stress can have a negative or positive impact on psychology and physiology [4].

In addition, medical personnel also need to attention the level of job satisfaction, because of knowing the job satisfaction of a medical worker, it can be known how the attitude of individual job. Job satisfaction of a medical staff depends on one's personality in terms of expectations, needs or values of his work, a situation of work, and social environment (**Ghazawi, 2008**). In many cases, high work conflicts and low job satisfaction can also affect of work stress, which is will effect and impacted to the performance of all members of the organization.

The purpose of this study was to obtain empirical evidence regrading the effect of work conflict and job satisfaction on the performance of medical personnel. The result of this study are expected to be able to provide benefits to health care facilities, so as be able to manage problems related to Human Resources within the scope of medical personnel.

II. LITERATURE REVIEW

A. *Work Conflict*

In a sociological perspective, social processes will naturally move in two contradictory directions, namely first moving towards the creation of social harmony or social integration where individuals or groups will unite a coexist with one another, and both move towards social conflict were individuals or groups will have gaps with another, both closed and hidden or open [7]. Robbins [4] explains that conflict is a process of interaction that occurs as a result of a discrepancy between two opinions or different point of view that affect several partirs involved both positively and negatively. Robbins also said that conflict within an organization can be called The Conflict Paradoks, the meaning of a view that in one side of a conflict can result in improving a group's performance, but on the other hand many groups and organizations strive to minimize and avoid conflict.

B. *Job Satisfaction*

Job satisfaction is a person's attitude in any organization to his job. In other words, how a person feels, thinks, and acts in life is the first determinant and how a person will think and feel about a job (**Ghazawi, 2008**). A person's job satisfaction depends on the difference between expectations, needs or values with what according to his views or perceptions has been achieved through his work. So, a person will feel satisfaction if there is no difference between what is desired and what actually happens, on the contrary, if there is a difference between what is desired and reality, then someone will feel dissatisfaction. It can be concluded that what is meant by job satisfaction is a collection of feelings and beliefs held by an employee, both pleasant (positive emotions) and unpleasant (negative emotions) about hiswork.

Job satisfaction is influenced by (1) personality which is a person's persoective formed because of feelings, thoughts, and beliefs, including

: utilization of abilities, work performance, progress, work creativity and independence in carrying out tasks, (2) value which is tthe values of one;s work that are intinsic or extrinsic, consisting of : rewards, recognition, responsibility, job security, and social services, (3) work situation are formed because of the work, colleagues work or team work, supervisors, subordinates and physical conditions, consisting of : authority, relations with superiors, technical supervision, diversity of task, and work conditions, and the last (4) social influence is the influence that a formed because of colleagues a team, groups and organizational culture, including : activities, policies, coworkers, moral values and status (**Ghazawi, 2008**).

C. *Job Stress*

Stres will always follow someone in their daily ativities. From the perspective , stress is something that is unpleasant or can bother him. Meanwhile, stated by Ivancevich et al ([11]in Nur, [6]), stress can be described as a feeling of tension, anxiety or worry, all feelings are manifestations of stressful experiences, a complex programmed to perceive threats that can produce results positive or negative. This means that stress can have a negative or positive impact on psychological and physiological [6].

Stress measurement techniques are by using PSQ (Perceived Stress Questionnaire) by Herbert and Carsten [8] including : (1) stress reaction is a reaction of an individual's stress level in the workplace that is related to perceived

anxiety, tension and excitement someone at work when carrying out office tasks, (2) *perceived* environmental stressor demands is a felling of stress due to environmental demands. An employee will feel emotional exhaustion and work results that are not optimal due to excessive organizational demands.

D. Performance

Performance is about doing of work and the results achieved from the job. Managing performance should be carried out collaboratively and cooperatively between employees, leaders and organizations, through understanding and explaining performance in a framework for jointly planned goals, standards and competencies. Ivancevich et al ([11]in Nur, [6]) stated that in assessing employee performance based on specifict behaviour descriptions, such as, (1) Quantity of work is the ability of comleting work, (2) Quality of work is the quality of achieved based on a conditions of suitability and readiness, (3) Knowledge of job is the area of knowledge about work and skills, (4) Personal qualities is related of personality, leadership, hospitality, and personal integrity, (5) Cooperation is the willingness to cooperate with others member of the organization, (6) Dependability is awareness and can be trusted in terms of attendance and completing work, (7) Initiative is the enthusiasm for carrying out new tasks and enlarging its responsibiliyies.

E. Research Design

The rasionale and focus of this research is to examine the effect of the independent variables is Work Conflict, Job Satisfaction and Job Stress as moderating variables that hav an influence on the Performance of the Meddical Personnel as dependent variables. The study used the research model as depicted in Figure 1:

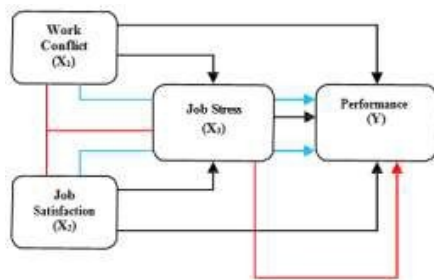

Figure 1: research model

F. Hypotheses

Based on the discussions and the research model, one may continue with the hypotheses of the research. The main hypotheses of the study can be stated as follows :

- H1 : Work conflicts have a positive and significant effect on jobstress.
- H2 : Job satisfaction has a negative and significant effect on job stress.
- H3 : Work conflicts have a negative and significant effect on the performance of medicalpersonnel.
- H4 : Job satisfaction has a positive and significant effect on the performance of medicalpersonnel.
- H5 : Job Stress has a negative and significant effect on the performance of medical personnel.
- H6 : Work conflicts have a negative and significant effect on the performance of medical personnel through job stress.
- H7 : Job satisfaction has a positive and significant effect on the performance of medical personnel through job stress.
- H8 : Work conflicts and job satisfaction have a positive and significant effect on the performance of medical personnel through job stress.

III. METHODOLOGY

This research is a descriptive study, with a quantitative approach. The data sources used in this study are primary data using a questionnaire through google form that is distributed online for data collection. The data collection period starts from March 25, 2019 to May 1, 2019. The population in this study are medical personnel, such as doctors / dentists, nurses / dental nurses, midwives, nutritionists, labolatory analysts, radiographers, and pharmacists who whorking in Healthcare Facilities in West Jakarta Region, with a sample of 205 respondents in the West Jakarta area.. Calculation of validity test and reability test is calculated using SPSS. To assess the item in the questionnaire valid or not, if the value of the corrected item total correlation is all greater than 0.200, then these items can be declared valid

[9]. In this study the results of the validity test on the questionnaire show that all the items are valid, because the value of the corrected item total correlation is greater than 0.200. for the results of the reliability analysis, the variables in the study have the value of Cronbach's Alpha. In this study the reliability test results show that all research variables in this study are reliable, because they have Cronbach's Alpha values exceeding 0.6 [10]. The variables in this study consisted of independent variables and dependent variables. Independent variables consist of Work Conflict (X1), Job Satisfaction (X2), and Job Stress (X3). And the dependent variable consists of Medical Personnel Performance (Y). This study uses a Likert scale measurement. Likert scale is used to determine the level of opinion or perception of respondents. Likert scale levels consist of Strongly Disagree (SD), Disagree (D), Neutral (N), Agree (A), and Strongly Agree (SA).

IV. RESULTS AND DISCUSSION

This research was conducted by distributing questionnaires using google form to medical personnel working in Health Care Facilities in the West Jakarta Region. The total respondents in this study were 205 respondents. Based on the data collected, it can be seen the majority of respondents in this study were female as many as 121 respondents (59,0%), aged 26-30 years as many 87 respondents (42,4%), work as nurse / dental nurse as many as 44 respondents (21,5%), with the last education strata 1 (S1) or bachelor's as many as 100 respondents (48,8%), and work period of more than 2 years as many as 133 respondents (64,9%).

The results of the research object description show the number of samples studied, minimum value, maximum value, mean value and standard deviation value. And obtained a mean value that shows the average rating of respondents from the results of the statements contained in the questionnaire, while the standard deviation value from the table shows how much deviation occurs in the statements contained in the questionnaire studied. Responses to research questionnaires are expressed on a Likert scale, starting from numbers 1 to 5, which were 1 shows strongly disagree, while the number 5 shows strongly agree. The mean value of the work conflict variable is 3.6355 and standard deviation is 0.82203. the mean value of the job satisfaction variable is 3.6312 and standard deviation is 0.63045. The mean value of the work stress variable is 3.2059 and standard deviation is 0.82531. the mean value of the variable performance of medical personnel is 3.7996 and standard deviation is 0.69294.

Table 1. Validity Test Results

Variabel	Statement	Corrected item total correlation	Results
Work Conflict	KK1	0,821	Valid
	KK2	0,781	Valid
	KK3	0.783	Valid
	KK4	0.802	Valid
	KK5	0.728	Valid
	KK6	0.745	Valid
	KK7	0.820	Valid
Job Satisfaction	KKJ1	0,659	Valid
	KKJ2	0.662	Valid
	KKJ3	0.665	Valid
	KKJ4	0.700	Valid
	KKJ5	0.697	Valid
	KKJ6	0.617	Valid
	KKJ7	0.738	Valid
	KKJ8	0.602	Valid
	KKJ9	0.610	Valid
	KKJ10	0.724	Valid
	KKJ11	0.718	Valid

	KKJ12	0.560	Valid
	KKJ13	0.686	Valid
	KKJ14	0.713	Valid
	KKJ15	0.670	Valid
	KKJ16	0.660	Valid
	KKJ17	0.687	Valid
	KKJ18	0.715	Valid
Job Stress	SK1	0.701	Valid
	SK2	0.657	Valid
	SK3	0.548	Valid
	SK4	0.674	Valid
	SK5	0.646	Valid
Medical Personnel Performance	KIN1	0.703	Valid
	KIN2	0.577	Valid
	KIN3	0.650	Valid
	KIN4	0.661	Valid
	KIN5	0.644	Valid
	KIN6	0.688	Valid
	KIN7	0.513	Valid
	KIN8	0.639	Valid
	KIN9	0.633	Valid
	KIN10	0.648	Valid
	KIN11	0.686	Valid
	KIN12	0.624	Valid

Based on Table 1 Test Validity Results, in this study the results of the validity test on the questionnaire indicate that all the items are valid, because the value of the corrected item total correlation is greater than 0.200. after analyzing the validity test results obtained r count or the results of corrected item total correlation ranged from 0.513 to 0.821. To assess the items in the questionnaire valid or not is if the value of corrected item total correlation are all greater than 0.200 then items it can be declared valid [9].

Table 2: Reliability Test Results

Variabel	Cronbach's Alpha	Results
Work Conflict	0,931	Reliable
Job Satisfaction	0,942	Reliable
Job Stress	0,840	Reliable
Medical Personnel Performance	0,908	Reliable

Based on Table 2, the results of the reliability test, for the results of the reliability analysis showed that the variables in the study had Cronbach's Alpha values ranging from 0.840 to 0.942. this value shows that all research variables in this study are reliable, because they have Cronbach's Alpha values exceeding 0.6 [10]. Calculation of validity test and reliability test is calculated using SPSS. The data used in this study is primary data by distributing questionnaires online using Google Form from data collection.

Data analysis in this study was obtained from the results of testing the research hypothesis. The purpose of conducting hypotheis testing is to find out whether the H0 hypothesis tested inthis study can be accepted or rejected. This can be seen by looking at the significance value (p) of each hypothesis test result. With an error tolerance limit (α) the acceptance and rejection of the hypotheis is 5%. If $p < \alpha$ or $< 0,05$ and / or $t > 1.96$ then there is significant influence between variable X on variable Y. To test the data, researchers use the Lisrel 22 aplication with the SEM (Structural Equation Model) technique. The model used is a model with observed variables. Following are the results of the research hypothesis test using the LISREL 22 application :

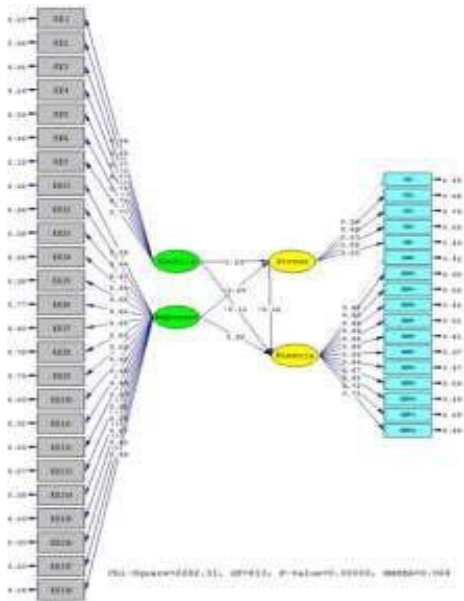

Figure 2: Estimates Test Results Using Lisrel

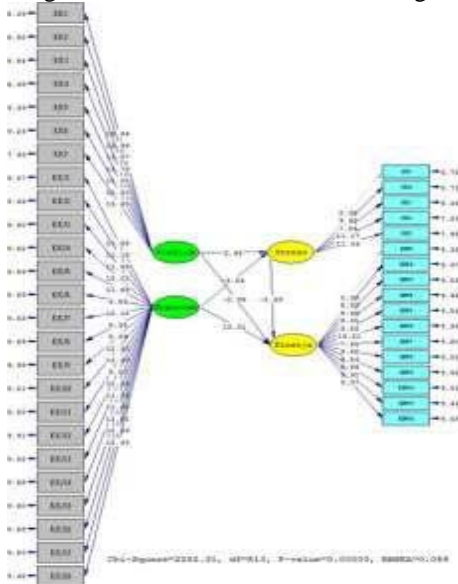

Figure 3: Results of the T-values Using Lisrel research hypothesis using the Lisrel 22 application. Figure 2 show the results of the test estimates of the research variables, and Figure 3 shows the results of the T-values test of the research variables. Values in this study, namely :

Table 3. Hypothesis Test Results

IV	DV	Estimate	T-values
Work Conflict	Job Stress	0.29	3.48
Job Satisfaction	Job Stress	-0.29	10.31
Work Conflict	Medical Personnel Performance	-0.11	-2.36
Job Satisfaction	Medical Personnel Performance	0.82	10.31
Job Stress	Medical Personnel Performance	-0.12	-2.63
Work Conflict	Performance of Medical Personnel through Job Stress	-0.04	-2.09
Job Satisfaction	Performance of Medical Personnel through Job Stress	0.04	2.23
Work Conflict and Job Satisfaction	Performance of Medical Personnel through Job Stress	-0.11 & 0.82	-2.36 & 10.31

Based on Tabel 3: Hypothesis Test Results using the Lisrel 22 application. The T-values of all variables in this study indicate that the results of all hypotheses will be accepted if the t values is greater than 1,96. From the table it can be concluded that the whole hypothesis can be accepted.

Hypothesis 1: Work Conflict has a positive and significant effect on Job Stress.

Hypothesis 1 is in line with the research conducted by Natemeyer et al (in yavas et al [12]) and Judge et al (in Roboth, [13]) which states that work conflict has a significant positive effect on work stress. Job demands are related to work pressure originating from the excessive workload that must be resolved in a short time so as to trigger work stress in medical personnel.

Hypothesis 2: Job Satisfaction has a negative and significant influence on Job Stress.

Hypothesis 2 shows that job satisfaction has a negative and significant effect on work stress. The results are the same as the research conducted by Sullivan and Bhagat [14] which states that job satisfaction and work stress have an inverse relationship. As supported by the opinion of Robbins [4] who argues that one's job satisfaction will have a direct impact on job stress, because if there is tension when doing work that will result in stress on the job, it will tend to reduce employee job satisfaction.

Hypothesis 3: Work Conflict has a negative and significant influence on the Performance of Medical Personnel.

Hypothesis 3 of these results is in line with the research conducted by Nur [6] which states that work conflict has a negative and significant effect on employee performance. This shows that the high and low work conflicts that occur in the work environment of a medical worker will have an influence on the performance of medical personnel in carrying out their work.

Hypothesis 4: Job Satisfaction has a negative and significant effect on the Performance of Medical Personnel.

Hypothesis 4, these results are supported by research conducted by Nur [6] which shows that job satisfaction has a positive and significant effect on employee performance. Dissatisfaction from a medical person in carrying out his work will bring unfavorable influence to a health care facility in carrying out a system to achieve a good goal. And also brings its own influence to the medical personnel themselves.

Hypothesis 5: Job Stress has a negative and significant effect on the performance of medical personnel.

Hypothesis 5 is in line with the research conducted by Nur [6] which states that work stress has a negative effect on employee performance. Jones in Murtiningrum [15] states that a profession related to the field of public service can be indicated to be more vulnerable to high levels of stressors because of the characteristics and nature of the work performed.

Hypothesis 6: Work Conflict has a negative and significant effect on the Performance of Medical Personnel through Job Stress.

Hypothesis 6 is in line with research conducted by Rosita [16] whose research results show that work conflict and work stress have a negative influence on performance. Work conflicts and work stress experienced by someone can

actually have a positive or negative impact depending on how an individual reacts to it[4].

Hypothesis 7: Job Satisfaction has a positive and significant influence on the Performance of Medical Personnel through Job Stress.

Hypothesis 7, the results of this study have similarities with the research conducted by Trianita[17] on the effect of work stress, motivation and job satisfaction on employee performance which shows that job satisfaction and stress have a positive effect on employee performance. This shows that the high and low job satisfaction of medical worker will have an influence and impact on the performance of the medical personnel themselves in carrying out their work, and can be influenced by the level of work stress experienced in doing work from a medical person.

Hypothesis 8: Work Conflict and Job Satisfaction have a positive and significant influence on the Performance of Medical Personnel through Job Stress.

These results have similarities with the research conducted by Nur [6] which states that conflict, work stress and job satisfaction simultaneously have a significant effect on employee performance.

Based on the results of hypothesis testing using the Lisrel 22 application, the variable job satisfaction has the highest estimates and t- values compared to work conflict and work stress. Thus the variable job satisfaction is the variable that most influences the performance of medical personnel.

V. CONCLUSIONS AND RECOMMENDATIONS

A. Conclusions

Based on the results of the research and discussion that have been conducted, it is concluded that there are effects of work conflict and job satisfactions on the performance of medical personnel through work stress. Based on the calculation results of the three variables, the highest variable that affects the performance of medical personnel is the variable job satisfaction. Viewed from the dimensions of job satisfaction, namely the dimensions of the social environment which includes activities and activities in work, policies implemented from the organization, mutual respect for individual rights of fellow medical personnel and being able to cooperate and interact well among medical personnel. This shows that the high and low job satisfaction of a medical worker will have an influence and impact on the performance of the medical personnel themselves in carrying out their work. By improving good communication between medical personnel and

colleagues and establishing good relations and coordination of work between units or divisions can improve the performance of medical personnel in a health care facility, which will have an impact on job satisfaction of medical personnel, if medical personnel feel valued by work what he does then this is the key to improving performance. Based on this, work conflicts, job satisfaction and work stress have a big influence on the performance of medical personnel.

B. Recommendations

Suggestions for health care facilities are to be able to create a comfortable work environment for medical personnel and establish good relationships by building bonding through organizational events to create a family atmosphere that can improve the performance of medical personnel and increase job satisfaction that can reduce work conflicts and work stress. Experienced by medical personnel in carrying out their work. Suggestions for further research is to develop other variables related to human resources in an organization that have not been studied in this research such as motivation variables and organizational culture as moderator variables that will affect performance. Suggestion for respondents in this case are medical personnel, in order to always establish clear and good communication and coordination between peers by building family and harmonious relationships between the other medical staff and other divisions are complementary and need each other in the course of a health care facility.

REFERENCES

- [1] Suroso, J. 2011. *Hubungan Persepsi tentang Jenjang Karir dengan Kepuasan Kerja dan Kinerja Perawat RSUD Banyumas*. Tesis tidak dipublikasikan. Depok : Fakultas Ilmu Keperawatan Universitas Indonesia.
- [2] Gatot Dewi Basmala and Adisasmito Wiku. 2005. *Hubungan Karakteristik Perawat, Isi Pekerjaan dan Lingkungan Pekerjaan Terhadap Kepuasan Kerja Perawat di Instalasi Rawat Inap RSUD Gunung Jati Cirebon*. Jurnal Fakultas Kesehatan Masyarakat Universitas Indonesia.
- [3] Henry R and Ongori P, 2009. *Organizational Conflict and its Effects on Organizational Performance*. Resemarch Journal of management 2 (1): 16-24.
- [4] Robbins P. Stepen, 2008. *Perilaku Organisasi*. Edisi Terjemahan. Salemba Group. Jakarta.
- [5] Akehurst, Gary, Comeche, Manuel, Jose, and Galindo, Angel, Miguel. 2009. *Job Satisfaction and Commitment in the Entrepreneurial SME*. To be Published Business Economic, Vol 31.
- [6] Nur Saina. 2013. *Konflik, Stress Kerja dan Kepuasan Kerja Pengaruhnya Terhadap Kinerja Pegawai Pada Universitas Khairun Ternate*. Jurnal Universitas Sam Ratulangi Manado.
- [7] Rezi Erdiansyah. 2014. *Tinjauan Teoritis dan Identifikasi Potensi Penelitian Dalam Kajian Konflik Organisasi*. Jurnal STIE Putra Perdana Indonesia.
- [8] Herbert M and Carsten W, 2005. *The Virtue And Vice of Workplace Conflict : Counterpoint Food For (Pessimistic) Thought*. Journal of Organizational Behavior, hal 5-18.
- [9] Nisfiannoor, M. (2013). *Pendekatan Statistik Modern untuk Ilmu Sosial*. Jakarta: Salemba Humanika.
- [10] Sarjono, H. & Julianita, W. (2011). *SPSS vs LISREL: Sebuah Pengantar, Aplikasi untuk Riset*. Salemba Empat, Jakarta.
- [11] Ivancevich M. John, Konopaske, Robert, and Matteson, T Michael, 2007. *Organizational Behavior and Management*. Seventh Editions Terjemahan Jilid 1 oleh Gina Gania, Gelora Aksara Pratama, Jakarta.
- [12] Yavas, U & Babakus, E. 2008. "Attitudinal And Behavioral Consequences of Work-Family Conflict And Family-Work Conflict: Does Gender Matter?" International Journal of Service Industry Management. Vol 19.No.1.
- [13] Roboth, Jane Y. 2015. *Analysis of Work Family Conflict, Work Stress and Performance of Women in a Double Role at the Compassion East Indonesia Foundation*. Journal of Business Research and Management Vol.13, No. 1. 2015:33- 46.
- [14] Sullivan, Sherry E, Rabi S. Bhagat, 1992, "Organizational Stress, Job Satisfaction and Job Performance: Where Do We Go From Here?". Journal Of Management, Vol. 18, No.2,353-374.
- [15] Murtiningrum, Afina. 2005. *Analisis Pengaruh Konflik Pekerjaan-Keluarga Terhadap Stress Kerja Dengan Dukungan Sosial Sebagai Variabel Moderasi (Studi Kasus Pada Guru Kelas 3 SMP Negeri di Kabupaten Kendal)*. Jurnal Universitas Diponegoro Semarang.
- [16] Rosita Sari. 2012. *Pengaruh Konflik Peran Ganda dan Stress Kerja Terhadap Kinerja Dosen Wanita di Fakultas Ekonomi Universitas Jambi*. Jurnal Manajemen Bisnis. Volume 2 No. 22. Edisi Oktober 2012.
- [17] Trianita, Mery. 2007. *Pengaruh Stress Kerja, Motivasi dan Kepuasan Kerja terhadap Kinerja Karyawan Bank Nagari Cabang Utama BPD Sumatra Barat*. Tesis Pasca Sarjana Program Magister Management, Universitas Andalas Padang (Tidak dipublikasikan).
- [18] Swansburg, R.C. 2000. *Kepemimpinan dan Manajemen Keperawatan untuk Perawat Klinis*. Alih Bahasa Suharyati Samba. Jakarta : EGC.
- [19]. Potter, P.A. and Perry, A. G. 2005. *Fundamental of nursing: concepts, process and practice*, Harcourt Australia : Mosby.
- [20]. Ghazzawi, Issam. 2008. *Job Sattisfaction Antecedents and Consequences : A New Coceptual Framework and Research Agenda*. The Business Review, Cambridge.
- [21]. Robbins P. Stepen, 2011. *Perilaku Organisasi*. Edisi Terjemahan. Salemba Group. Jakarta.

SURAT TUGAS

NOMOR : 100-Dir/157/PPS-UNTAR / vIII/2020

Pimpinan Program Pascasarjana Universitas Tarumanagara menugaskan Saudara:

Dr. Rezi Erdiansyah, M.Si.

Untuk mengikuti TICASH 2019 dan bentuk publikasi artikel sebagai berikut :

Judul Artikel : Effect of Conflict, Job Satisfaction, and Stress on Medical Staff
Performance (Study in the Health Facilities, West Jakarta) :

Tanggal 20 Mei 2020

Media Publikasi : Proceedings of the Tarumanagara International Conference on the
Applications of Social Sciences and Humanities (TICASH 2019)

Link Artikel (url) : <https://www.atlantis-press.com/proceedings/ticash-19/125940651>

Penulis Dewi Sri Haryati, Rezi Erdiansyah

Demikian Surat Tugas ini dibuat, untuk dilaksanakan dengan sebaik-baiknya dan penuh rasa tanggung jawab serta melaporkan hasil kegiatan kepada Direktur Program Pascasarjana.

Jakarta, 15 Juli 2020

Direktur



Dr. Indra Widjaja, MM

Tembusan:

1. Kaprodi MM